

# BR16

ES|FR|IT|EN|DE|PT

INDICADOR

INDICATEUR

INDICATORE

INDICATOR

ANZEIGE

VISOR

V.4.3  
23/01/2023



marca propiedad de | est une marque de | marchio di proprietà di |  
trade mark propriety of | Warenzeichen Proprietät von | marca registada proprietade de:

Pol. Empordà Internacional C/ Molló, 3  
17469 VILAMALLA - (Girona) SPAIN  
T. (34) 972 527 212

**GIROPES**



## ES

## INDICE

<b>1. ESPECIFICACIONES</b>	6
<b>2. ALIMENTACIÓN</b>	6
<b>3. ANTES DE SU UTILIZACIÓN</b>	6
<b>4. CONSUMO</b>	6
<b>5. CONEXIÓN DE LA CÉLULA DE CARGA AL INDICADOR</b>	6
<b>6. DESCRIPCIÓN DEL DISPLAY Y DEL TECLADO</b>	8
<b>7. MODO CUENTA PIEZA</b>	8
<b>8. CONFIGURACIÓN DE PARÁMETROS</b>	9
8.1 CUENTAS INTERNAS (A/D)   <i>UF-1</i>	9
8.2 CONFIGURACIÓN DE LOS LÍMITES DE PESO (SUPERIOR E INFERIOR)   <i>UF-2</i>	9
8.3 AUTODESCONEXIÓN AUTOMÁTICA   <i>UF-3</i>	10
8.4 CONFIGURACIÓN DE LA ILUMINACIÓN DEL DISPLAY   <i>UF-4</i>	10
8.5 FUNCIÓN HOLD   <i>UF-5</i>	10
8.6 SALIDA DE DATOS RS-232   <i>UF-6</i>	11
8.7 CONFIGURACIÓN DE LA VELOCIDAD DEL CONVERTIDOR   <i>UF-7</i> (*)	14
8.8 CIEGA CERO   <i>UF-8</i> (*)	14
8.9 CONFIGURACIÓN DE LA GRAVEDAD   <i>UF-9</i> (*)	15
<b>9. CALIBRACIÓN ( SOLO PARA EL PERSONAL AUTORIZADO) (*)</b>	15
9.1 CALIBRACIÓN DE CERO+PESO   <i>ECF-1</i>	15
9.2 CALIBRACIÓN DE CERO   <i>ECF-2</i>	15
9.3 CALIBRACIÓN DE PESO   <i>ECF-3</i>	15
<b>10. PARÁMETROS TÉCNICOS</b>	16
<b>11. MENSAJES DE ERROR</b>	<b>20</b>
<b>12. GARANTÍA</b>	21

## FR

<b>1. SPÉCIFICATIONS</b>	22
<b>2. ALIMENTATION</b>	22
<b>3. AVANT SON UTILISATION</b>	22
<b>4. CONSOMMATION</b>	22
<b>5. CONNEXION DE LA CAPTEURS DE CHARGE À L'INDICATEUR</b>	22
<b>6. DESCRIPTION DE L'AFFICHAGE ET DU CLAVIER</b>	24
<b>7. MODE COMPTE PIÈCES</b>	24
<b>8. CONFIGURATION DE PARAMÈTRES</b>	25
8.1 COMPTES INTERNES (A/D)   <i>UF-1</i>	25
8.2 CONFIGURATION DES LIMITES DE POIDS (SUPÉRIEURE ET INFÉRIEURE)   <i>UF-2</i>	25
8.3 AUTODÉCONNEXION AUTOMATIQUE   <i>UF-3</i>	26
8.4 CONFIGURATION DE L'ÉCLAIRAGE DE L'AFFICHAGE   <i>UF-4</i>	26
8.5 FONCTION HOLD   <i>UF-5</i>	26
8.6 SORTIE DE DONNÉES RS-232   <i>UF-6</i>	27
8.7 CONFIGURATION DE LA VITESSE DU CONVERTISSEUR   <i>UF-7</i> (*)	30
8.8 ZÉRO AVEUGLE   <i>UF-8</i> (*)	30
8.9 CONFIGURATION DE LA GRAVITÉ   <i>UF-9</i> (*)	30
<b>9. ÉTALONNAGE (UNIQUEMENT POUR LE PERSONNEL AUTORISÉ) (*)</b>	31
9.1 ÉTALONNAGE DE ZÉRO+POIDS   <i>ECF-1</i>	31
9.2 ÉTALONNAGE DE ZÉRO   <i>ECF-2</i>	31
9.3 ÉTALONNAGE DE POIDS   <i>ECF-3</i>	31
<b>10. PARAMÈTRES TECHNIQUES</b>	31
<b>11. MESSAGES D'ERREUR</b>	36
<b>12. GARANTIE</b>	37

<b>IT</b>	<b>1. SPECIFICHE</b>	38
	<b>2. ALIMENTAZIONE</b>	38
	<b>3. PRIMA DELL'USO</b>	38
	<b>4. CONSUMO</b>	38
	<b>5. COLLEGAMENTO DELLA CELLA DI CARICO ALL'INDICATORE</b>	38
	<b>6. DESCRIZIONE DEL DISPLAY E DELLA TASTIERA</b>	40
	<b>7. MODALITÀ CONTAPEZZI</b>	40
	<b>8. CONFIGURAZIONE DEI PARAMETRI</b>	41
	8.1 CALCOLI INTERNI (A/D)   <i>UF-1</i>	41
	8.2 CONFIGURAZIONE DEI LIMITI DI PESO (SUPERIORE E INFERIORE)   <i>UF-2</i>	41
	8.3 DISATTIVAZIONE AUTOMATICA   <i>UF-3</i>	42
	8.4 CONFIGURAZIONE DELL'ILLUMINAZIONE DEL DISPLAY   <i>UF-4</i>	42
8.5 FUNZIONE HOLD   <i>UF-5</i>	42	
8.6 USCITA DEI DATI RS-232   <i>UF-6</i>	43	
8.7 CONFIGURAZIONE DELLA VELOCITÀ DEL CONVERTITORE   <i>UF-7 (*)</i>	46	
8.8 CIECA ZERO   <i>UF-8 (*)</i>	46	
8.9 CONFIGURAZIONE DELLA GRAVITÀ   <i>UF-9 (*)</i>	47	
<b>9. CALIBRAZIONE (SOLO PER IL PERSONALE AUTORIZZATO) (*)</b>	47	
9.1 CALIBRAZIONE DELLO ZERO+PESO   <i>ECC-1</i>	47	
9.2 CALIBRAZIONE DELLO ZERO   <i>ECC-2</i>	47	
9.3 CALIBRAZIONE DEL PESO   <i>ECC-3</i>	47	
<b>10. PARAMETRI TECNICI</b>	48	
<b>11. MESSAGGI DI ERRORI</b>	52	
<b>12. GARANZIA</b>	53	

<b>EN</b>	<b>1. SPECIFICATIONS</b>	54
	<b>2. POWER</b>	54
	<b>3. BEFORE USE</b>	54
	<b>4. CONSUMPTION</b>	54
	<b>5. CONNECTING THE CHARGING CELL TO THE INDICATOR</b>	54
	<b>6. DISPLAY AND KEYBOARD DESCRIPTION</b>	56
	<b>7. PIECE COUNTING MODE</b>	57
	<b>8. PARAMETER CONFIGURATION</b>	57
	8.1 INTERIOR CALCULATIONS (A/D)   <i>UF-1</i>	57
	8.2 CONSTRUCTION OF WEIGHT LIMIT (HIGH AND LOWER)   <i>UF-2</i>	57
	8.3 AUTOMATIC DISARMING   <i>UF-3</i>	58
	8.4 CONFIGURING DISPLAY LIGHTING   <i>UF-4</i>	58
8.5 HOLD FUNCTION   <i>UF-5</i>	58	
8.6 USCITA DEI DATI RS-232   <i>UF-6</i>	59	
8.7 CONVERTER SPEED CONFIGURATION   <i>UF-7 (*)</i>	62	
8.8 BLIND ZERO   <i>UF-8 (*)</i>	62	
8.9 CONFIGURATION OF GRAVITY   <i>UF-9 (*)</i>	62	
<b>9. CALIBRATION (ONLY FOR AUTHORIZED PERSONNEL) (*)</b>	63	
9.1 ZERO CALIBRATION + WEIGHT   <i>ECC-1</i>	63	
9.2 ZERO CALIBRATION   <i>ECC-2</i>	63	
9.3 WEIGHT CALIBRATION   <i>ECC-3</i>	63	
<b>10. TECHNICAL PARAMETERS</b>	63	
<b>11. ERROR MESSAGES</b>	67	
<b>12. WARRANTY</b>	68	

DE

INHALTSVERZEICHNIS	
<b>1. SPEZIFIKATIONEN</b>	69
<b>2. STROMZUFUHR</b>	69
<b>3. VOR DER INBETRIEBNAHME</b>	69
<b>4. VERBRAUCH</b>	69
<b>5. ANSCHLUSS DER WAAGE AN DIE ANZEIGE</b>	69
<b>6. BESCHREIBUNG DISPLAY UND TASTATUR</b>	71
<b>7. STÜCKZÄHLMODUS</b>	71
<b>8. KONFIGURATION DER PARAMETER</b>	72
8.1 INTERNES ZÄHLEN (A/D)   <i>UF-1</i>	72
8.2 KONFIGURATION DER GEWICHTSGRENZEN (HÖCHST- UND MINDESGEWICHT)   <i>UF-2</i>	72
8.3 AUTOMATISCHES ABSCHALTEN   <i>UF-3</i>	73
8.4 KONFIGURATION DER DISPLAYBELEUCHTUNG   <i>UF-4</i>	73
8.5 HOLD-FUNKTION   <i>UF-5</i>	74
8.6 DATENAUSGANG RS-232   <i>UF-6</i>	74
8.7 KONFIGURATION DER GESCHWINDIGKEIT DES STROMRICHTERS   <i>UF-7 (*)</i>	77
8.8 NULL-TEILWERT   <i>UF-8 (*)</i>	77
8.9 KONFIGURATION DER GRAVITATION   <i>UF-9 (*)</i>	78
<b>9. KALIBRIERUNG (NUR FÜR AUTORISIERTES PERSONAL) (*)</b>	78
9.1 KALIBRIERUNG VON NULL + GEWICHT   <i>ECF-1</i>	78
9.2 KALIBRIERUNG VON NULL   <i>ECF-2</i>	78
9.3 KALIBRIERUNG DES GEWICHTS   <i>ECF-3</i>	78
<b>10. TECHNISCHE PARAMETER</b>	79
<b>11. FEHLERMELDUNGEN</b>	84
<b>12. GARANTIE</b>	85

PT

<b>1. ESPECIFICAÇÕES</b>	86
<b>2. ALIMENTAÇÃO ELÉTRICA</b>	86
<b>3. ANTES DA UTILIZAÇÃO</b>	86
<b>4. CONSUMO</b>	86
<b>5. LIGAÇÃO DA CÉLULA DE CARGA AO INDICADOR</b>	86
<b>6. DESCRIÇÃO DO VISOR E DO TECLADO</b>	88
<b>7. MODO DE CONTAGEM DE PEÇAS</b>	88
<b>8. CONFIGURAÇÃO DE PARÂMETROS</b>	89
<b>8.1 CONTAS INTERNAS (A/D)   <i>UF-1</i></b>	89
8.2 CONFIGURAÇÃO DOS LIMITES DE PESO (SUPERIOR E INFERIOR)   <i>UF-2</i>	89
8.3 DESLIGAR AUTOMÁTICO   <i>UF-3</i>	90
8.4 CONFIGURAÇÃO DA ILUMINAÇÃO DO VISOR   <i>UF-4</i>	90
8.5 FUNÇÃO HOLD   <i>UF-5</i>	90
8.6 SAÍDA DE DATOS RS-232   <i>UF-6</i>	90
8.7 CONFIGURAÇÃO DA VELOCIDADE DO CONVERSOR   <i>UF-7 (*)</i>	94
8.8 ZERO CEGO/INVISÍVEL   <i>UF-8 (*)</i>	94
8.9 CONFIGURAÇÃO DA GRAVIDADE   <i>UF-9 (*)</i>	95
<b>9. CALIBRAÇÃO (APENAS PARA PESSOAL AUTORIZADO) (*)</b>	95
9.1 CALIBRAÇÃO DO ZERO + PESO   <i>ECF-1</i>	95
9.2 CALIBRAÇÃO DO ZERO   <i>ECF-2</i>	95
9.3 CALIBRAÇÃO DO PESO   <i>ECF-3</i>	95
<b>10. PARÂMETROS TÉCNICOS</b>	96
<b>11. MENSAGENS DE ERRO</b>	100
<b>12. GARANTIA</b>	101

## 1. ESPECIFICACIONES

### BR16

Precisión	Clase III
Rango de sensibilidad de la célula de carga	1.5 ~ 3.0mV/V
No linealidad	≤0.01%F.S
Voltaje célula	DC 5V
Escalón	1/2/5 (seleccionable)
Frecuencia de muestreo	20 veces por segundo (fuera de meteorología)
Resolución interna	300.000~600.000

## 2. ALIMENTACIÓN

### BR16

Entrada	100/240VAC
Salida	12V/1A
Batería recargable	6V/4Ah

## 3. ANTES DE SU UTILIZACIÓN

- 1) Situar la balanza sobre una superficie firme y llana, no exponerla en ambientes con vibraciones.
- 2) Utilizar una fuente eléctrica independiente, evitar perturbaciones eléctricas.
- 3) No colocar ningún objeto sobre la plataforma en el momento de poner en marcha el indicador.
- 4) Por favor, permita que la balanza se precaliente durante 2-3 minutos antes de su utilización.
- 5) Evitar cambios de temperatura muy bruscos y corrientes de aire.
- 6) No sobrecargar la balanza, nunca exceder la capacidad máxima.

## 4. CONSUMO

- Consumo normal en reposo: approx. 12mA - 333h
- Consumo con la retroiluminación: aprox. 36mA - 111,11h
- Consumo con la retroiluminación y salida RS-232: aprox. 48mA-83h
- Duración de la batería: sin la retroiluminación, aprox. 320 horas

## 5. CONEXIÓN DE LA CÉLULA DE CARGA AL INDICADOR

- 1) El conector de la célula de carga es de 7 pins.
- 2) Cuando el indicador está trabajando, no quitar el conector de la célula de carga, este acto podría dañar el equipo

### ESQUEMA CÉLULA DE 7 PINS

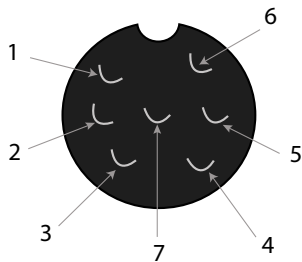
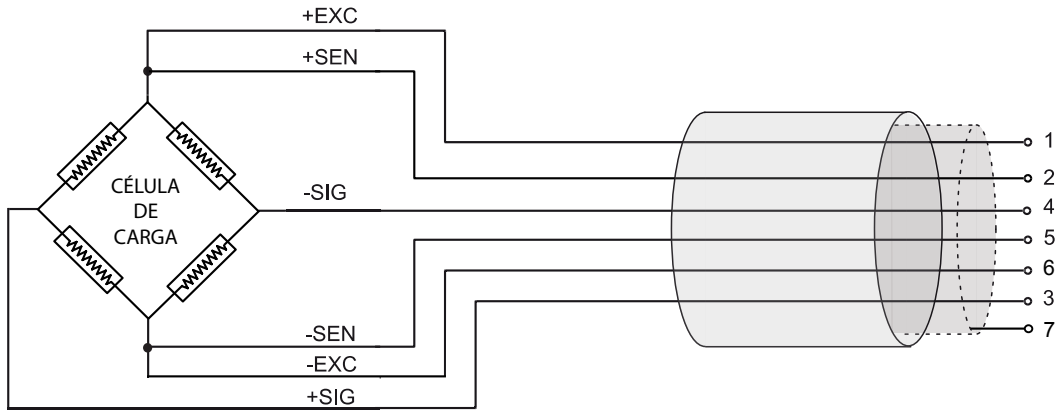

PIN 1	EXC +
PIN 2	SEN +
PIN 3	SIG +
PIN 4	SIG -
PIN 5	SEN -
PIN 6	EXC -
PIN 7	GND

### CONNEXIÓN RS232

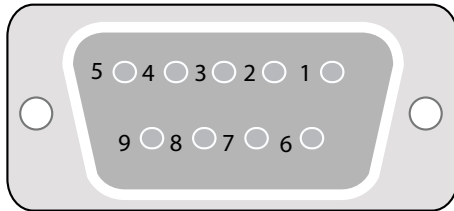

2	Tx
3	Rx
5	GND

### PROTOCOLO

UART signal of EIA-RS232 C

SEÑAL UART DE EIA-RS232 C	
Salida serie	1200 / 2400 / 4800 / 9600 / 19200 / 34800 bps
Bits de datos	8 bits
Bits de paridad	No
Bits de stop	1 bit

#### INFORMACIÓN CABECERAS

Cabecera 1 (2 BYTES)	Cabecera 2 (2 BYTES)
OL – Sobrecarga	
ST – Estable	NT – Peso neto
US – INESTABLE	GS – Peso bruto

## 6. DESCRIPCIÓN DEL DISPLAY Y DEL TECLADO

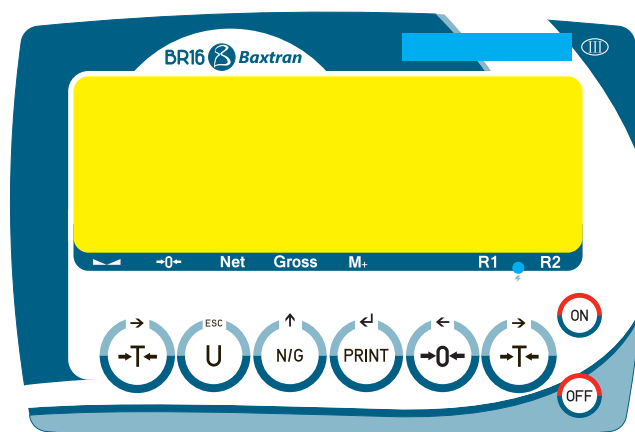

Pulsar esta tecla para encender la balanza.



Mantener pulsada esta tecla durante 2 segundos para apagar el indicador.



**1º función** Para cambiar de unidad de pesaje.

**2º función** Para salir de un menú.



**1º función** Para poner la lectura del display a cero "0", el valor del display tiene que ser menor al  $\pm 2\%$  de la capacidad máxima.

**2º función** Para desplazarse un espacio hacia la izquierda o hacia abajo dentro del modo programación.



**1º función** Para sustraer el peso de un contenedor.

**2º función** Para desplazarse un espacio hacia la derecha o hacia arriba dentro del modo programación.



**1º función** Para visualizar el peso neto o bruto de un producto cuando se ha realizado una Tara. Cuando se visualiza el peso bruto del producto las demás teclas quedan deshabilitadas.

**2º función** Para incrementar los valores dentro del modo programación.



**1º función** Transmisión manual de datos a través del puerto RS-232 a un PC o impresora y según modo elegido.

**2º función** Tecla de confirmación dentro del modo programación.

## 7. MODO CUENTA PIEZA

1. Presione la tecla hasta que la pantalla muestre Pcs.
2. Presione sucesivamente para seleccionar la cantidad de piezas de la muestra. La pantalla mostrará sucesivamente C 10 / C 20 / C 50 / C 100 / C 200.
3. Sitúe la muestra sobre la plataforma, espere que se encienda el indicador de estabilidad y presione la tecla .
4. Sitúe el producto encima de la plataforma y la pantalla mostrará el número de piezas.



La acumulación y envío de datos dependerá del modo elegido en el apartado UF-6.

- Para volver al modo de pesaje normal, presione la tecla .
- Si desea volver al modo cuenta piezas, usando la misma muestra de referencia, presione nuevamente la tecla .
- Si desea cambiar la muestra de referencia, vuelva a repetir los pasos descritos anteriormente.



## 8. CONFIGURACIÓN DE PARÁMETROS

8.1	CUENTAS INTERNAS (A/D)	UF-1
8.2	CONFIGURACIÓN DE LOS LÍMITES DE PESO (SUPERIOR E INFERIOR)	UF-2
8.3	AUTODESCONEXIÓN AUTOMÁTICA	UF-3
8.4	CONFIGURACIÓN DE LA ILUMINACIÓN DEL DISPLAY	UF-4
8.5	FUNCIÓN HOLD	UF-5
8.6	SALIDA DE DATOS RS-232	UF-6
8.7	CONFIGURACIÓN DE LA VELOCIDAD RS-232	UF-7
8.8	PROMEDIO DEL CERO	UF-8
8.9	CONFIGURACIÓN DE LA GRAVEDAD	UF-9



Para acceder a la configuración de parámetros, pulsar al mismo tiempo las teclas  y .

Pulsar las teclas  y  para navegar por el menú (UF-1 ~ UF-9).









Pulsar la tecla  para acceder al parámetro y confirma.

Pulsar la tecla  para salir del menú y volver al modo de pesaje.

### 8.1 CUENTAS INTERNAS (A/D) | UF-1



1. Pulsar la tecla  para visualizar las cuentas internas de la balanza.
2. Para pasar al siguiente parámetro, pulsar la tecla  y la pantalla indicará el voltaje de la batería.
3. Pulsar la tecla  para volver al menú *UF*.



### 8.2 CONFIGURACIÓN DE LOS LÍMITES DE PESO (SUPERIOR E INFERIOR) | UF-2

1. Pulsar la tecla  para acceder al parámetro.
2. El display mostrará el mensaje "00000L" (Límite inferior).
3. Utilizar las teclas  y  para mover el cursor y la tecla  para seleccionar el número deseado.
4. Pulsar la tecla  para confirmar.
5. El display mostrará "00000H" (Límite superior).
6. Utilizar las teclas  y  para mover el cursor y la tecla  para seleccionar el número deseado.
7. Pulsar la tecla  para confirmar.
8. El display mostrará el valor

A B C  
0 0 0

(configuración de la alarma)

DISPLAY	VALOR	ESTABILIDAD	
A	0	no hace falta estabilidad para sonar	
	1	hace falta estabilidad para sonar	
B	0	siempre 0	
C	0	alarma apagada	
	1	alarma suena si está en la franja <b>Ok</b> (entre límites <b>Lo</b> y <b>Hi</b> )	
	2	alarma suena si está por debajo del límite inferior <b>Lo</b> o por encima del límite superior <b>Hi</b>	



9. Utilizar las teclas  y  para mover el cursor y la tecla  para seleccionar el número deseado.





10. Pulsar la tecla  para confirmar.

Las indicaciones en pantalla **Lo**, **Ok**, **Hi** aparecerán en pantalla según el peso.

### 8.3 AUTODESCONEXIÓN AUTOMÁTICA | UF-3



MODOS:



	Autodesconexión desactivada.
	Autodesconexión activada, la balanza se apagará automáticamente transcurrido 1 minuto sin ser utilizada. Seleccione el tiempo de autodesconexión entre 1 y 99 minutos.

1. Pulsar la tecla  para acceder al parámetro.
2. Utilizar las teclas  y  para mover el cursor y la tecla  para seleccionar el tiempo deseado.
3. Pulsar la tecla  para confirmar.

### 8.4 CONFIGURACIÓN DE LA ILUMINACIÓN DEL DISPLAY | UF-4



MODOS:

	Automática.
	Iluminación activada siempre.
	Iluminación desactivada.

1. Pulsar la tecla  para acceder al parámetro.
2. Pulsar la tecla  para seleccionar el modo deseado.
3. Pulsar la tecla  para confirmar.

### 8.5 FUNCIÓN HOLD | UF-5











Los modo **HOLD** permiten que, una vez retirado el objeto del plato, el display mantiene el peso fijado hasta la presión de , función muy útil para el pesaje de animales). **Nota: si usted ha activado el modo hold, NO PODRÁ UTILIZAR LA FUNCIÓN LÍMITES NI ACUMULACIÓN.**

1. Pulsar la tecla  para acceder al parámetro.
2. Pulsar la tecla  para seleccionar el modo deseado.
3. Pulsar la tecla para  confirmar.

**MODOS:**



- **HOLD 0** : Desactivado.
- **HOLD 1** : Animal en movimiento.
- **HOLD 2** : Valor de pico.
- **HOLD 3** : Hold estable.
- **HOLD 4** : Hold estable con auto cancelación a cero.

**HOLD 1.**

- Una vez se ha accedido a este parámetro, la pantalla muestra **Pct**,
- Use las teclas   y  para mover el cursor y la tecla  para seleccionar el valor del rango de HOLD deseado de 001 a 100.
- Pulsar la tecla  para confirmar.
- La pantalla mostrará **time 8**, use las teclas   y  para mover el cursor y la tecla  para seleccionar el número de repeticiones deseado durante el rango de hold.
- Pulsar la tecla  para confirmar.

*Ejemplo: Pct pequeño y time grande implica más precisión y mayor tiempo de estabilización.*

**8.6 SALIDA DE DATOS RS-232 | UF-6**

1. Pulsar la tecla  para acceder al parámetro.
2. Pulsar la tecla  para seleccionar la velocidad de transmisión deseada.
3. Pulsar la tecla  para confirmar.

**FORMATO DE LOS DATOS**

**Ningún formato**

**232 0** Salida RS-232 Desactivada

**Formato 1 PC**

FORMATO AUTOMÁTICO DE PESO O PIEZAS

ST,GS,+0003. 58 kg <CR><LF>

ST,GS,+0000250pcs <CR><LF>

ENVÍO DE TRAMA

**232 1** Envío de trama, sin acumulación, cuando consigue estabilidad con **formato 1**.

**232 2** Envío de trama continuo con **formato 1**.

**232 3** Envío de trama, sin acumulación, manual presionando la tecla  con **formato 1**.

**Formato 2 PC**

FORMATO AUTOMÁTICO DE PESO O PIEZAS

+0000.64kg<CR><LF>

+0000100pcs<CR><LF>

ENVÍO DE TRAMA

**232 4** Envío de trama, sin acumulación, cuando consigue estabilidad con **formato 2**.

**232 5** Envío de trama continuo con **formato 2**.

**232 6** Envío de trama, sin acumulación, manual presionando la tecla  con **formato 2**.

**Formato 3 impresora**

FORMATO AUTOMÁTICO DE PESO O PIEZAS

S/N	WT/kg	S/N	WT/pcs
0001	0.64	0001	20
0002	0.70	0002	21
0003	0.64	0003	45
-----		-----	
0003	1.98	0003	86

**232 7** Envío de trama y acumulación manual, pasando por cero y presionando la tecla  con **formato 3**.

0002 0.70

Si estando la pantalla a 0, se presiona dos veces seguidas la tecla  se imprime la línea de total.

-----  
0003 1.98

Y se borra la memoria de pesadas.

Nota: Acumulación y totalización no disponible para metrología legal.

ENVÍO DE TRAMA

**232 8** Envío de trama y acumulación automática a la estabilidad, pasando por 0 con **formato 3**.

0002 21

Si estando la pantalla a 0, se presiona dos veces seguidas la tecla  se imprime la línea de total.

-----  
0003 86

Y se borra la memoria de pesadas.

Nota: Acumulación y totalización no disponible para metrología legal

**Formato 4 impresora**

FORMATO AUTOMÁTICO  
DE PESO O PIEZAS

TICKET NO.0003	
G	0.64kg
T	0.00kg
N	0.64kg
TOTAL NUMBER OF TICKETS 0003	
TOTAL	
NET	1.92

TICKET NO.0002	
G	20pcs
T	0pcs
N	20pcs
TOTAL NUMBER OF TICKETS 0002	
TOTAL	
NET	40

**NOTA:** totalización no disponible en metrología legal.

ENVÍO DE TRAMA

**232 9**

Envío de trama y acumulación manual, pasando por cero y presionando la tecla  con **formato 4**

TICKET NO.0003	
G	0.64kg
T	0.00kg
N	0.64kg

Si estando la pantalla a 0, se presiona dos veces seguidas la tecla



se imprime el resumen de tickets.

En nuevas Versiones es posible que el usuario tenga que presionar



y al mostrar el número y peso de las acumulaciones,

presione  para imprimir los valores y también borrar la memoria al mismo tiempo.

TOTAL NUMBER OF TICKETS 0003	
TOTAL	
NET	1.92

Y se borra la memoria de pesadas

**NOTA:** totalización no disponible en metrología legal.

ENVÍO DE TRAMA

**232 10**

Envío de trama y acumulación automática a la estabilidad, pasando por cero y presionando la tecla  con **formato 4.**

TICKET NO.0002	
G	20pcs
T	0pcs
N	20pcs

Si estando la pantalla a 0, se presiona dos veces seguidas la tecla



se imprime el resumen de tickets.

En nuevas Versiones es posible que el usuario tenga que presionar



y al mostrar el número y peso de las acumulaciones,

presione  para imprimir los valores y también borrar la memoria al mismo tiempo.

TOTAL NUMBER OF TICKETS 0003	
TOTAL	
NET	1.92

Y se borra la memoria de pesadas

**NOTA:** totalización no disponible en metrología legal.

**NOTA:** Cada vez que se hace una acumulación, el visor muestra el total acumulado durante 3 segundos.

### FORMATO 1 (232 1 ~ 3):

18 BYTES ASCII PARA LAS UNIDADES kg, g, t, lb

1	2	,	1	2	,	1	2	3	4	5	6	7	8	1	2	CR	LF
Cabecera 1		Cabecera 2		Datos										Unidad			

21 BYTES ASCII PARA LAS UNIDADES tl, T, lboz

1	2	,	1	2	,	1	2	3	4	5	6	7	8	9	1	2	3	4	CR	LF
Cabecera 1		Cabecera 2		Datos										Unidad						

19 BYTES ASCII PARA LA UNIDAD pcs

1	2	,	1	2	,	1	2	3	4	5	6	7	8	1	2	3	CR	LF
Cabecera 1		Cabecera 2		Datos										Unidad				

### FORMATO 2 (232 4 ~ 6):

12 BYTES ASCII PARA LAS UNIDADES kg, g, t, lb

1	2	3	4	5	6	7	8	1	2	CR	LF
Datos								Unidad			



15 BYTES ASCII PARA LAS UNIDADES tl, T, lboz

1	2	3	4	5	6	7	8	9	1	2	3	4	CR	LF
Datos									Unidad					

13 BYTES ASCII PARA LA UNIDAD pcs

1	2	3	4	5	6	7	8	1	2	3	CR	LF
Datos								Unidad				

## 8.7 CONFIGURACIÓN DE LA VELOCIDAD DEL CONVERTIDOR | UF--7 (\*)

1. Pulsar la tecla  para acceder al parámetro.
2. Pulsar la tecla  para seleccionar el modo deseado.

Modo 1	Normal
Modo 2	Rápido
Modo 3	Lento

3. Pulsar la tecla  para confirmar.

## 8.8 CIEGA CERO | UF--8 (\*)



Muestra 0 en pantalla hasta llegar a la siguiente división seleccionada. Empezando a mostrar valores a partir de esta división.

Ejemplo:





báscula con e=2g

ciega en 5 divisiones

Mostrará 0 hasta llegar a 2x5=10g el primer valor que mostrará será 12g.

1. Pulsar la tecla  para acceder al parámetro.
2. Pulsar la tecla  para seleccionar.
3. Pulsar la tecla  para confirmar.

## 8.9 CONFIGURACIÓN DE LA GRAVEDAD | *UF-9 (\*)*



1. Pulsar la tecla  para acceder al parámetro.
2. Para cambiar el valor, pulsar la tecla , seguidamente utilizar las teclas, utilizar las teclas  y  para mover el cursor y la tecla para seleccionar el número deseado.

## 9. CALIBRACIÓN ( SOLO PARA EL PERSONAL AUTORIZADO) (\*)



<b>9.1</b>	<b>CALIBRACIÓN DE CERO + PESO (SPAN)</b>	<i>ECF-1</i>
<b>9.2</b>	<b>CALIBRACIÓN DE CERO</b>	<i>ECF-2</i>
<b>9.3</b>	<b>CALIBRACIÓN DE PESO (SPAN)</b>	<i>ECF-3</i>

0. Mover el switch interno a CAL ON.

1. Dentro del modo normal de pesaje, pulsar las teclas  y , el display mostrará el mensaje **ECF-1**.
2. Pulsar las teclas  y  para seleccionar la función deseada: **ECF-1, ECF-2 o ECF-3**

### 9.1 CALIBRACIÓN DE CERO+PESO | *ECF-1*

Pulsar la tecla , el display mostrará CALZ.

Pulsar la tecla , para poner a cero la lectura del display.

Pulsar las teclas  y  para mover el cursor.

Pulsar la tecla , introducir el valor de la pesa de calibración.

Colocar la pesa de calibración sobre la plataforma y pulsar la tecla  para efectuar la calibración una vez la lectura sea estable.

### 9.2 CALIBRACIÓN DE CERO | *ECF-2*

Pulsar la tecla , el display mostrará CALZ.

Pulsar la tecla , para poner la lectura del display a cero.

Pulsar la tecla , para efectuar la calibración.

### 9.3 CALIBRACIÓN DE PESO | *ECF-3*

Pulsar la tecla , el display mostrará el valor del peso de calibración

Pulsar las teclas  y  para mover el cursor.

Pulsar la tecla , para modificar el valor de la pesa de calibración.

Pulsar la tecla , para confirmar.

Colocar la pesa de calibración sobre la plataforma y pulsar la tecla  para efectuar la calibración una vez la

## 10. PARÁMETROS TÉCNICOS



NO MODIFIQUE LOS PARÁMETROS TÉCNICOS SI NO ES ESTRICTAMENTE NECESARIO. UNA MALA CONFIGURACIÓN DE ESTA SECCIÓN PUEDE PROVOCAR UN MAL FUNCIONAMIENTO DE LA BALANZA.



En el caso de visores verificados, abra el visor y cambie el interruptor de calibración a la posición CAL ON. En este caso, recuerde que romper los precintos conlleva la pérdida de la verificación.





### ENTRAR Y SALIR DE LA CALIBRACIÓN

#### DISPLAY

#### DESCRIPCIÓN y SECUENCIA DE USO

LF 1

- CON EL INTERRUPTOR INTERNO EN POSICION CAL ON.
- Con el visor apagado, presione y mantenga presionada la tecla  y encendida de equipo, cuando la pantalla muestre **100 t**, suelte la tecla .

Presione la tecla  para acceder a las teclas  o  para cambiar de parámetro y la tecla  para salir del menú y el visor se reiniciará automáticamente.

### CALIBRACIÓN DE PESO LF 1

#### DISPLAY

#### DESCRIPCIÓN y SECUENCIA DE USO

LF 1

La calibración se puede realizar con cualquier peso, pero el peso no debe ser inferior a 1/3 de la máxima capacidad ni nunca debe ser sobrepasada.

CAL 2

- Presione la tecla  para empezar la calibración de zero (presione  para salir de la calibración y volver al menú LF1)



150.00 kg

- Utilice ,  y , **0 ~ 9** y después  para introducir el peso con el que se hará la calibración. (Presione  para salir de la calibración y volver al menú LF1)



150.00 kg

- Sitúe el peso requerido sobre la báscula tal y cómo indica el display parpadeante.



150.00 kg

- Una vez estabilice, presione  para calibrarla. (presione ESC para salir de la calibración y volver al menú LF1).



LA CALIBRACIÓN SE TERMINARÁ Y LA BÁSCULA VOLVERÁ AL MODO DE PESAJE AUTOMÁTICAMENTE.



## CONFIGURACIÓN LF2

### DISPLAY

### DESCRIPCIÓN Y SECUENCIA DE USO

#### PRIMER PASO

262 144

#### SEGUNDO PASO

1 0 0 0 0 1

A B C D E F

- VISUALIZACIÓN DE LAS CUENTAS INTERNAS
- POSIBLES VALORES DE LOS PARÁMETROS DE CONFIGURACIÓN

A: Sistema Métrico	0:NO	1: kg	2:T	3:g
B: Sistema Americano	0:NO	1: lb	2:lb oz	
C: otras unidades	0:NO	1: TW kg	2:HK kg	3:VISS
D: PCS	0:OFF	1: ON		
E: doble rango	0:OFF	1: multi intervalo	2:multi rango	
F: unidades de calibración		1: usar unidades métricas	2: usar unidades americanas	

lb oz no se pueden seleccionar como unidades de calibración.

La bascula no nos dejará continuar hasta el próximo paso si hay un error durante la programación.

#### TERCER PASO

LF2



262 144



10000 1



000000kg



d 0.0kg



div 01



LF2



Después de entrar los parámetros LF2, el visor mostrará la última configuración guardada. Todos los pasos deben completarse, si no el visor continuará con la configuración anterior.

Proceda con la calibración de peso después de LF2.

- Presione la tecla para empezar y mostrará el VALOR INTERNO. Presione para salir del menú y la báscula se reiniciará automáticamente.

- Presione para continuar con la configuración. (presione para salir de la configuración y volver al menú LF2).

- Utilice , y , y después para seleccionar las UNIDADES Y MODO DE PESAJE según la tabla anterior. (presione para salir de la calibración y volver al menú LF2).

- Utilice , y , y después para seleccionar la CAPACIDAD MÁXIMA, teniendo en cuenta el número de decimales que va a seleccionar en el siguiente paso. (presione para salir de la calibración y volver al menú LF2).

- Utilice , y después para mover el punto decimal. (presione para salir de la configuración y volver al menú LF2).

- Utilice y después para cambiar el escalón (presione para salir de la configuración y volver al menú LF2).

- Utilice , y para continuar con otras configuraciones o presione para salir del menú y la báscula se reiniciará automáticamente).

## VELOCIDAD DEL CONVERTIDOR AD *LF 4*















**SPEED 1** velocidad estándar 15Hz.

**SPEED 2** alta velocidad 30Hz.

**SPEED 3** baja velocidad 7.5Hz















\*Esta función queda bloqueada cuando UF-5 se encuentra en modo HOLD 1.

\*El valor de fábrica es 1

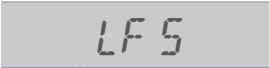
DISPLAY	DESCRIPCIÓN Y SECUENCIA DE USO
 	<ul style="list-style-type: none"> <li>• Presione  para empezar o  para salir del menú y la báscula se reiniciará automáticamente.</li> </ul>
 	<ul style="list-style-type: none"> <li>• Utilice  y después  para seleccionar la velocidad del convertidor AD (presione  para salir de la configuración y volver al menú LF4)</li> </ul>
	<ul style="list-style-type: none"> <li>• Utilice ,  y después  para continuar con otros ajustes o presione  para salir del menú y la báscula se reiniciará automáticamente.</li> </ul>

## CIEGA *LF 5*

DISPLAY	DESCRIPCIÓN Y SECUENCIA DE USO
	<p><b>ZP 0</b> OFF</p> <p><b>ZP 1</b> Una división no se mostrará estando a cero</p> <p><b>ZP 2</b> Dos divisiones no se mostrarán estando a cero</p> <p><b>ZP 3</b> Tres divisiones no se mostrarán estando a cero</p> <p><b>ZP 4</b> Cuatro divisiones no se mostrarán estando a cero</p> <p><b>ZP 5</b> Cinco divisiones no se mostrarán estando a cero</p> <p>*Esta función queda bloqueada cuando UF-5 se encuentra en modo HOLD 1</p> <p>*El valor de fábrica es ZP 0</p>

DISPLAY	DESCRIPCIÓN Y SECUENCIA DE USO
 	<ul style="list-style-type: none"> <li>• Presione  para empezar o  para salir del menú y la báscula se reiniciará automáticamente.</li> </ul>
 	<ul style="list-style-type: none"> <li>• Utilice  y después  para seleccionar cuantas divisiones nos e mostrarán a cero. (presione <b>ESC</b> para salir de la configuración y volver al menú LF4)</li> </ul>
 	<ul style="list-style-type: none"> <li>• Utilice ,  y después  para continuar con otros ajustes o presione  para salir del menú y la báscula se reiniciará automáticamente.</li> </ul>

## CONFORMIDAD DE APROBACIÓN **LF 6**

### DISPLAY

0M LF 6



### DESCRIPCIÓN Y SECUENCIA DE USO

**nonE** Versión no verificada    **OIML** versión verificada  
**NO MODIFIQUE BAJO NINGÚN CONCEPTO ESTE PARÁMETRO.**

El cambio de este parámetro implica el bloqueo de ciertas funcionalidades.

## GRAVEDAD **LF 7**

\*Introduzca la gravedad de su zona antes de realizar la primera calibración.

\*Introduzca la gravedad de destino después de realizar la calibración.

\*El valor de gravedad será denegado si es mayor que 9.83217 (gravedad de polo) o inferior que 9.78031 (gravedad del ecuador).

Valor de fábrica: 9.801

### DISPLAY

LF 7



-00-

9.8035



9.8035



### DESCRIPCIÓN Y SECUENCIA DE USO

- Presione para continuar o para salir del menú y la báscula se reiniciará automáticamente.

- La pantalla mostrará el número de pre-calibración durante un segundo.

- Presione para continuar.

- Utilice , y , **0 ~ 9** y después para introducir el valor de gravedad.. (presione ESC para salir de la configuración y volver al menú LF 7).

## CERO INICIAL **LF 8**

**SEtZ Y** resetea el punto de cero cada vez que se reinicia la báscula

**SEtZ n** reseteo del punto cero OFF

### DISPLAY

LF 8



SetZ y



LF 8

### DESCRIPCIÓN y SECUENCIA DE USO

- Presione para empezar o para salir del menú y la báscula se reiniciará automáticamente.

- Utilice y después para seleccionar el modo de cero inicial. (presione para salir de la configuración y volver al menú LF8)

- Utilice , y después para continuar con otros ajustes o presione para salir del menú y la báscula se reiniciará automáticamente.

## 11. MENSAJES DE ERROR

MENSAJES	DESCRIPCIÓN
	Punto cero demasiado alto
	Punto cero demasiado alto
	Punto cero demasiado alto
	Punto cero demasiado bajo
	Punto cero demasiado bajo
	El peso no es estable.
	El código interno no es estable
	Sobrecarga
	Sobrecarga
	Sobrecarga
	Corrección de linealidad incorrecta o cancelación de corrección de linealidad
	El peso es demasiado bajo
	El código interno es demasiado bajo
	E2ROM anormal
	El precio total es más de 999999
	El volumen de la batería es demasiado bajo

## **12. GARANTÍA**

Este indicador está garantizado contra todo defecto de fabricación y de material, por un periodo de 1 año a partir de la fecha de entrega.

Durante este periodo, GIROPÈS, se hará cargo de la reparación del indicador.

Esta garantía no incluye los daños ocasionados por uso indebido o sobrecargas.

La garantía no cubre los gastos de envío (portes) necesarios para la reparación del indicador.

# 1. SPÉCIFICATIONS

## BR16

	Précision	Classe III
	Plage de sensibilité de la capteurs de charge	1.5 ~ 3.0mV/V
	Non linéarité	≤0.01%F.S
	Voltage capteurs	DC 5V
	Échelon	1/2/5 (sélectionnable)
	Fréquence d'échantillonnage	20 fois par seconde (au delà de la météorologie)
	Résolution interne	300.000~600.000

# 2. ALIMENTATION

## BR16

	Entrée	100/240VAC
	Sortie	12V/1A
	Batterie rechargeable	6V/4Ah

# 3. AVANT SON UTILISATION

- 1) Placez la balance sur une surface ferme et de niveau et ne l'exposez pas à des environnements vibratoires.
- 2) Utilisez une source d'alimentation indépendante, éviter les chocs électriques.
- 3) Ne placez pas d'objets sur la plateforme au moment de la mise en marche de l'indicateur.
- 4) Laissez la balance préchauffer pendant 2-3 minutes avant utilisation.
- 5) Évitez les changements brusques de température et les courants d'air.
- 6) Évitez de surcharger la balance, ne dépassez jamais la capacité maximale.

# 4. CONSOMMATION

- Consommation normale au repos: environ 12mA - 333h
- Consommation avec rétroéclairage: environ 36mA - 111,11h
- Consommation avec rétroéclairage et sortie RS-232: environ 48mA-83h
- Durée de la batterie, environ 320 heures

# 5. CONNEXION DE LA CAPTEURS DE CHARGE À L'INDICATEUR

- 1) Le connecteur de la capteurs de charge est à 7 broches.
- 2) Lorsque l'indicateur est en marche, ne retirez pas le connecteur de la capteurs de charge, cet acte pourrait endommager l'équipement

## SCHÉMA CAPTEURS À 7 BROCHES

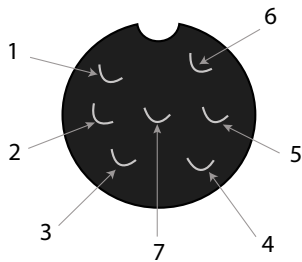
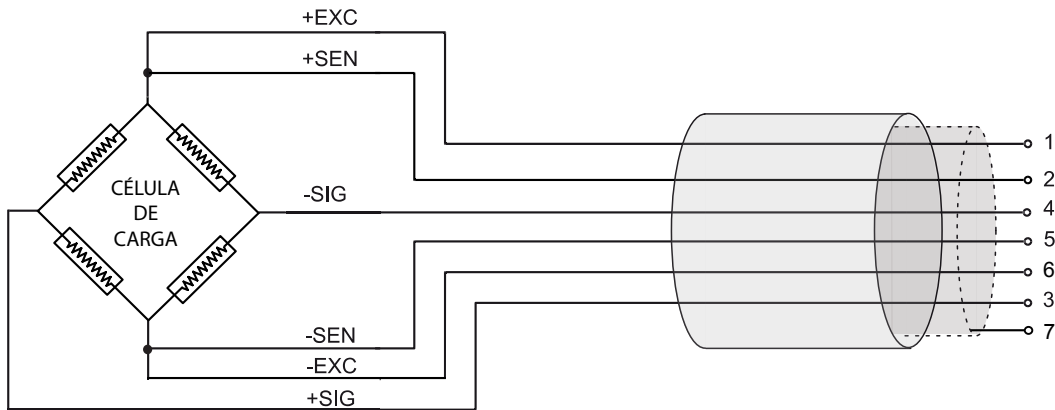

PIN 1	EXC +
PIN 2	SEN +
PIN 3	SIG +
PIN 4	SIG -
PIN 5	SEN -
PIN 6	EXC -
PIN 7	GND

## CONNEXION RS232

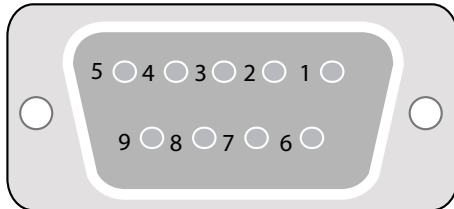

2	Tx
3	Rx
5	GND

## PROTOCOLE

signal UART de EIA-RS232 C

SIGNAL UART DE EIA-RS232 C	
Sortie série	1200 / 2400 / 4800 / 9600 / 19200 / 34800 bps
Bits de données	8 bits
Bits de parité	No
Bits de stop	1 bit

### INFORMATION TÊTES

Tête 1 (2 OCTETS)	Tête 2 (2 OCTETS)
OL – Surcharge	
ST – Stable	NT – Poids net
US – INSTABLE	GS – Poids brut

## 6. DESCRIPTION DE L'AFFICHAGE ET DU CLAVIER

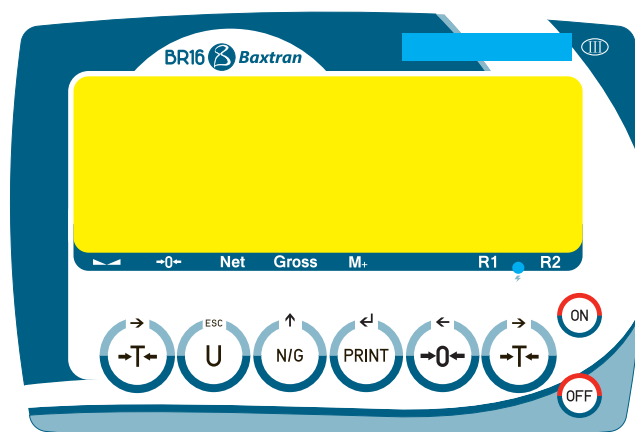

Appuyez sur cette touche pour faire mettre la balance en marche.



Maintenez cette touche appuyée pendant 2 secondes pour éteindre l'indicateur.



**1ère fonction** Pour changer l'unité de pesage.

**2ème fonction** Pour quitter un menu.



**1ère fonction** Pour régler l'affichage de lecture à zéro « 0 », la valeur d'affichage doit être inférieure à  $\pm 2\%$  de la capacité maximale.

**2ème fonction** Pour déplacer un espace vers la gauche ou vers le bas dans le mode de programmation.



**1ère fonction** Pour soustraire le poids d'un récipient.

**2ème fonction** Pour déplacer un espace vers la droite ou vers le bas dans le mode de programmation.



**1ère fonction** Pour afficher le poids net ou brut d'un produit lorsqu'on a effectué une tare. Quand on visualise le poids brut du produit, les autres touches sont désactivées.

**2ème fonction** Pour augmenter les valeurs dans le mode de programmation.



**1ère fonction** Transmission manuelle des données via le port RS-232 à un PC ou une imprimante et selon le mode choisi.

**2ème fonction** Touche de confirmation dans le mode de programmation.

## 7. MODE COMPTE PIÈCES

- Appuyez sur la touche jusqu'à ce que l'écran affiche Pcs.
- Appuyez successivement sur pour sélectionner la quantité de pièces de l'échantillon. L'écran affichera successivement C 10 / C20 / C 50 / C 100 / C 200.
- Placez l'échantillon sur la plateforme, attendez que l'indicateur de stabilité s'allume et appuyez sur la touche .
- Placez le produit sur la plateforme et l'écran affichera le nombre de pièces.

L'accumulation et l'envoi de données dépendront du mode sélectionné dans la section [UF-6](#).

- Pour revenir au mode de pesage normal, appuyez sur la touche .
- Si vous souhaitez revenir au mode de comptage de pièces, en utilisant le même échantillon de référence, appuyez à nouveau sur la touche .
- Si vous voulez changer l'échantillon de référence, répétez les étapes ci-dessus.



## 8. CONFIGURATION DE PARAMÈTRES

8.1	COMPTES INTERNES (A/D)	UF-1
8.2	CONFIGURATION DES LIMITES DE POIDS (SUPÉRIEURE ET INFÉRIEURE)	UF-2
8.3	AUTOCONNEXION AUTOMATIQUE	UF-3
8.4	CONFIGURATION DE L'ÉCLAIRAGE DE L'AFFICHAGE	UF-4
8.5	FONCTION HOLD	UF-5
8.6	SORTIE DE DONNÉES RS-232	UF-6
8.7	CONFIGURATION DE LA VITESSE RS-232	UF-7
8.8	MOYENNE DU ZÉRO	UF-8
8.9	CONFIGURATION DE LA GRAVITÉ	UF-9

Pour accéder à la configuration des paramètres, appuyez simultanément sur les touches  et .

Appuyez sur les touches  et  pour naviguer dans le menu (UF-1 ~ UF-9).









Appuyez sur la touche  pour accéder au paramètre et confirmez.

Appuyez sur la touche  pour quitter le menu et revenir au mode de pesage.

### 8.1 COMPTES INTERNES (A/D) | UF-1



1. Appuyez sur la touche  pour afficher les comptes internes de la balance.
2. Pour passer au paramètre suivant, appuyez sur la touche  et l'écran indiquera la tension de la batterie.
3. Appuyez sur la touche  pour revenir au menu *UF*.



### 8.2 CONFIGURATION DES LIMITES DE POIDS (SUPÉRIEURE ET INFÉRIEURE) | UF-2

1. Appuyez sur la touche  pour accéder au paramètre.
2. L'écran affichera « 00000L » (limite inférieure).
3. Utilisez les touches  et  pour déplacer le curseur et la touche  pour sélectionner le numéro désiré.
4. Appuyez sur la touche  pour confirmer.
5. L'écran affichera « 00000H » (Limite supérieure).
6. Utilisez les touches  et  pour déplacer le curseur et la touche  pour sélectionner le numéro désiré.
7. Appuyez sur la touche  pour confirmer.
8. L'écran affichera la valeur.

A B C  
0 0 0

(configuration de l'alarme)

AFFICHAGE	VALEUR	STABILITÉ	
A	0	pas besoin de stabilité pour sonner	
	1	besoin de stabilité pour sonner	
B	0	toujours 0	
C	0	alarme éteinte	
	1	alarme retentit s dans la bande <b>Ok</b> (entre limites <b>Lo</b> et <b>Hi</b> )	
	2	alarme retentit si vous êtes en dessous de la limite inférieure <b>Lo</b> ou au-dessus de la limite supérieure <b>Hi</b>	



9. Utilisez les touches  et  pour déplacer le curseur et la touche  pour sélectionner le numéro désiré.





10. Appuyer sur la touche  pour confirmer.

Les indications à l'écran **Lo**, **Ok**, **Hi** apparaîtront à l'écran selon le poids.

### 8.3 AUTODÉCONNEXION AUTOMATIQUE | UF-3



MODES:



	Autodéconnexion désactivée.
	Autodéconnexion activée, la balance s'éteindra automatiquement après 1 minute sans utilisation. Sélectionnez le temps d'autodéconnexion entre 1 et 99 minutes.

1. Appuyez sur la touche  pour accéder au paramètre.
2. Utilisez les touches  et  pour déplacer le curseur et la touche  pour sélectionner le temps désiré.
3. Appuyer sur la touche  pour confirmer.

### 8.4 CONFIGURATION DE L'ÉCLAIRAGE DE L'AFFICHAGE | UF-4



MODES:

	Automatique.
	Éclairage toujours activé.
	Éclairage désactivé.

1. Appuyez sur la touche  pour accéder au paramètre.
2. Appuyez sur la touche  pour sélectionner le mode désiré.
3. Appuyez sur la touche  pour confirmer.

### 8.5 FONCTION HOLD | UF-5









Les modes **HOLD** permettent, une fois l'objet retiré du plateau, que l'affichage garde le poids fixe jusqu'à appuyer à nouveau sur  (fonction **U**), fonction très utile pour le pesage des animaux. **Remarque: Si vous avez activé le mode Hold, VOUS NE POURREZ PAS UTILISER LA FONCTION LIMITE OU ACCUMULATION.**

1. Appuyez sur la touche  pour accéder au paramètre.
2. Appuyez sur la touche  pour sélectionner le mode désiré..
3. Appuyez sur la touche  pour confirmer.

## MODES:



- **HOLD 0**: Désactivé.
- **HOLD 1**: Animal en mouvement.
- **HOLD 2**: Valeur de pic.
- **HOLD 3**: Hold stable.
- **HOLD 4**: Hold stable avec auto-annulation à zéro.

**HOLD 1.**

- Une fois que vous avez accédé à ce paramètre, l'écran affiche **Pct**,
- Utilisez les touches  et  pour déplacer le curseur et la touche  pour sélectionner la valeur de la plage HOLD désirée de 00 à 100.
- Appuyer sur la touche  pour confirmer.
- L'écran affichera **time 8**, utilisez les touches  et  pour déplacer le curseur et la touche  pour sélectionner le nombre de répétitions au cours de la plage de hold.
- Appuyer sur la touche  pour confirmer.

Exemple: Pct petits et time grand implique plus de précision et plus de temps de stabilisation.

**8.6 SORTIE DE DONNÉES RS-232 | UF--6**

1. Appuyez sur la touche  pour accéder au paramètre.
2. Appuyez sur la touche  pour sélectionner la vitesse de transmission désirée.
3. Appuyez sur la touche  pour confirmer.

**FORMAT DES DONNÉES****Aucun format**

**232 0** Sortie RS-232 Désactivée

**Format 1 PC**

FORMAT AUTOMATIQUE DE  
POIDS OU PIÈCES

ST,GS,+0003 . 58 kg <CR><LF>

ST,GS,+0000250pcs <CR><LF>

**232 1** Envoi de trame, sans accumulation, quand on obtient une stabilité avec le **format 1**.  
**232 2** Envoi de trame continue avec **format 1**.  
**232 3** Envoi de trame, sans accumulation, manuel en appuyant sur la touche  avec **format 1**.

**Format 2 PC**

FORMAT AUTOMATIQUE DE  
POIDS OU PIÈCES

+0000.64kg <CR><LF>

+0000100pcs <CR><LF>

**232 4** Envoi de trame, sans accumulation, quand on obtient une stabilité avec le **format 2**.  
**232 5** Envoi de trame continue avec **format 2**.  
**232 6** Envoi de trame, sans accumulation, manuel en appuyant sur la touche  avec **format 2**.

**Format 3 imprimante**

FORMAT AUTOMATIQUE  
DE POIDS OU PIÈCES

S/N	WT/kg	S/N	WT/pcs
0001	0.64	0001	20
0002	0.70	0002	21
0003	0.64	0003	45
-----		-----	
0003	1.98	0003	86

**232 7** Envoi de trame et accumulation manuelle, en passant par zéro et en appuyant sur la touche  avec **format 3**.

0002	0.70
------	------

Si l'écran est à 0, on appuie deux fois de suite sur la touche  et la ligne totale est imprimée.

-----	
0003	1.98

Et on efface la mémoire des pesées.

Remarque : Accumulation et totalisation non disponible pour la métrologie légale.

ENVOI DE TRAME

**232 8** Envoi de trame et accumulation automatique à la stabilité, en passant par 0 avec **format 3**.

0002	21
------	----

Si l'écran est à 0, on appuie deux fois de suite sur la touche  et la ligne totale est imprimée.

-----	
0003	86

Et on efface la mémoire des pesées.

Remarque : Accumulation et totalisation non disponible pour la métrologie légale.

**Format 4 imprimante**

FORMAT AUTOMATIQUE  
DE POIDS OU PIÈCES

TICKET NO.0003	
G	0.64kg
T	0.00kg
N	0.64kg

TICKET NO.0002	
G	20pcs
T	0pcs
N	20pcs

TOTAL NUMBER OF TICKETS 0003	
TOTAL	
NET	1.92

TOTAL NUMBER OF TICKETS 0002	
TOTAL	
NET	40



**REMARQUE:** totalisation non disponible en métrologie légale.

ENVOI DE TRAME

**232 9**

Envoi de trame et accumulation manuelle en passant par zéro et en appuyant sur la touche  avec **format 4**

Si l'écran est à 0, on appuie deux fois de suite sur la touche  et le résumé des tickets est imprimé.

Sur les nouvelles versions, il est possible que l'utilisateur doive appuyer  sur et lors de l'affichage du nombre et du poids des accumulations, appuyer sur  pour imprimer les valeurs et également supprimer la mémoire en même temps.

Et on efface la mémoire des pesées.

**REMARQUE:** totalisation non disponible en métrologie légale.

TICKET NO.0003
G 0.64kg
T 0.00kg
N 0.64kg



TOTAL NUMBER OF TICKETS 0003
TOTAL NET 1.92

ENVOI DE TRAME

**232 10**

Envoi de trame et accumulation automatique à la stabilité, en passant par zéro et en appuyant sur la touche  avec **format 4**.

Si l'écran est à 0, on appuie deux fois de suite sur la touche  et le résumé des tickets est imprimé.

Sur les nouvelles versions, il est possible que l'utilisateur doive appuyer  sur et lors de l'affichage du nombre et du poids des accumulations, appuyer sur  pour imprimer les valeurs et également supprimer la mémoire en même temps.

Et on efface la mémoire des pesées.

**REMARQUE:** totalisation non disponible en métrologie légale.

TICKET NO.0002
G 20pcs
T 0pcs
N 20pcs

TOTAL NUMBER OF TICKETS 0002
TOTAL NET 40

**REMARQUE:** Chaque fois qu'une accumulation est terminée, le viseur affiche le total cumulé pendant 3 secondes.

**FORMAT 1 (232 1 ~ 3):**

18 OCTETS ASCII POUR LES UNITÉS kg, g, t, lb

1	2	,	1	2	,	1	2	3	4	5	6	7	8	1	2	CR	LF
Tête 1		Tête 2		Données								Unité					

21 OCTETS ASCII POUR LES UNITÉS tl, t, lboz

1	2	,	1	2	,	1	2	3	4	5	6	7	8	9	1	2	3	4	CR	LF
Tête 1		Tête 2		Données								Unité								

19 OCTETS ASCII POUR L'UNITÉ pcs

1	2	,	1	2	,	1	2	3	4	5	6	7	8	1	2	3	CR	LF
Tête 1		Tête 2		Données								Unité						

**FORMAT 2 (232 4 ~ 6):**

12 OCTETS ASCII POUR LES UNITÉS kg, g, t, lb

1	2	3	4	5	6	7	8	1	2	CR	LF
Données								Unité			

15 OCTETS ASCII POUR LES UNITÉS tl, t, lboz

1	2	3	4	5	6	7	8	9	1	2	3	4	CR	LF
Données									Unité					

13 OCTETS ASCII POUR L'UNITÉ pcs

1	2	3	4	5	6	7	8	1	2	3	CR	LF
Données								Unité				

**8.7 CONFIGURATION DE LA VITESSE DU CONVERTISSEUR | UF-7 (\*)**

1. Appuyez sur la touche  pour accéder au paramètre.
2. Appuyez sur la touche  pour sélectionner le mode désiré.

Mode 1 Normal

Mode 2 Rapide

Mode 3 Lent

3. Appuyez sur la touche  pour confirmer.

**8.8 ZÉRO AVEUGLE | UF-8 (\*)**

Affiche 0 jusqu'à atteindre la prochaine division sélectionnée. En commençant à afficher des valeurs à partir de cette division.

Exemple:





balance avec e=2g

aveugle en 5 divisions

Il affichera 0 jusqu'à atteindre  $2 \times 5 = 10$ g la première valeur qui sera affichée sera 12g.

1. Appuyez sur la touche  pour accéder au paramètre.
2. Appuyez sur la touche  pour sélectionner.
3. Appuyez sur la touche  pour confirmer.

**8.9 CONFIGURATION DE LA GRAVITÉ | UF-9 (\*)**

1. Appuyez sur la touche  pour accéder au paramètre.
2. Pour modifier la valeur, appuyez sur la touche , puis utilisez les touches, utilisez les touches  et  pour déplacer le curseur et la touche pour sélectionner le numéro désiré.

## 9. ÉTALONNAGE (UNIQUEMENT POUR LE PERSONNEL AUTORISÉ) (\*)



9.1	ÉTALONNAGE DE ZÉRO+POIDS (PORTÉE)	<i>ECF-1</i>
9.2	ÉTALONNAGE DE ZÉRO	<i>ECF-2</i>
9.3	ÉTALONNAGE DE POIDS (PORTÉE)	<i>ECF-3</i>

0. Déplacer le switch interne sur CAL ON.

1. Dans le mode de pesage normal, appuyez sur les touches  et , l'écran affichera le message **ECF – 1**.

2. Appuyez sur les touches  et  pour sélectionner la fonction désirée: **ECF-1, ECF-2 o ECF-3**

### 9.1 ÉTALONNAGE DE ZÉRO+POIDS | *ECF-1*

Appuyez sur la touche , l'écran affichera CALZ.

Appuyez sur la touche , pour mettre à zéro la lecture de l'affichage.

Appuyez sur les touches  et  pour déplacer le curseur

Appuyez sur la touche  introduire la valeur du poids d'étalonnage.

Placez le poids d'étalonnage sur la plateforme et appuyez sur la touche  pour effectuer l'étalonnage une fois que la lecture est stable.

### 9.2 ÉTALONNAGE DE ZÉRO | *ECF-2*

Appuyez sur la touche , l'écran affichera CALZ.

Appuyez sur la touche , pour mettre la lecture de l'affichage à zéro.

Appuyez sur la touche , pour effectuer l'étalonnage.

### 9.3 ÉTALONNAGE DE POIDS | *ECF-3*

Appuyez sur la touche , l'écran affichera la valeur du poids d'étalonnage.

Appuyez sur les touches  et  pour déplacer le curseur.

Appuyez sur la touche  pour modifier la valeur du poids d'étalonnage.

Appuyez sur la touche , pour confirmer.

Placez le poids d'étalonnage sur la plateforme et appuyez sur la touche  pour effectuer l'étalonnage une fois que la lecture est stable.

## 10. PARAMÈTRES TECHNIQUES









NE MODIFIER LES PARAMÈTRES TECHNIQUES QUE SI CELA EST STRICTEMENT NÉCESSAIRE. UNE MAUVAISE CONFIGURATION DE CETTE SECTION PEUT PROVOQUER UN MAUVAIS FONCTIONNEMENT DE LA BALANCE.

















Dans le cas de viseurs vérifié, ouvrez l'écran et changez l'interrupteur d'étalonnage à la position ON. Dans ce cas, rappelez-vous que de briser

les joints d'étanchéité implique la perte de la vérification.

## ENTRER DANS ET QUITTER L'ÉTALONNAGE

ÉCRAN	DESCRIPTION ET SÉQUENCE D'UTILISATION
	<ul style="list-style-type: none"> <li>• AVEC INTERRUPTEUR INTERNE EN POSITION CAL ON.</li> <li>• Avec le viseur éteint, appuyez et maintenez la touche  appuyée et sous tension lorsque l'écran affiche <i>100 t</i>, relâchez la touche .</li> </ul>
	<p>Appuyez sur la touche  pour accéder aux touches  ou  pour modifier le paramètre et la touche  pour quitter le menu et le viseur redémarrera automatiquement.</p>

## ÉTALONNAGE DE POIDS *LF 1*

ÉCRAN	DESCRIPTION ET SÉQUENCE D'UTILISATION
	L'étalonnage peut être effectué avec n'importe quel poids, mais le poids ne doit pas être inférieur à 1/3 de la capacité maximale ou ne doit jamais être dépassé.
 	• Appuyez sur la touche  pour démarrer l'étalonnage du zéro (appuyez sur  pour quitter l'étalonnage et revenir au menu LF1)
 	• Utilisez  ,  et  , <b>0 ~ 9</b> puis  pour entrer le poids avec lequel sera fait l'étalonnage. (Appuyez sur  pour quitter l'étalonnage et revenir au menu LF1)
 	• Placez le poids requis sur la balance, comme indiqué par l'affichage clignotant.
 	• Une fois établi, appuyez sur  péalonner. (appuyez sur ESC pour quitter l'étalonnage et revenir au menu LF1).
	L'ÉTALONNAGE SE TERMINERA ET LA BALANCE REPASSERA AUTOMATIQUÉMENT AU MODE DE PESAGE.



## CONFIGURATION LF 2

## ÉCRAN

## DESCRIPTION ET SÉQUENCE D'UTILISATION

## PREMIÈRE ÉTAPE

262 144

## DEUXIÈME ÉTAPE

1 0 0 0 0 1

A B C D E F

- VISUALISATION DES COMPTES INTERNES
- POSSIBLES VALEURS DES PARAMÈTRES DE CONFIGURATION

A: Système métrique	0:NO	1: kg	2:T	3:g
B: Système américain	0:NO	1: lb	2:lb oz	
C: autres unités	0:NO	1: TW kg	2:HK kg	3:VISS
D: PCS	0:OFF	1: ON		
E: double plage	0:OFF	1: multi intervalle	2: multi plage	
F: unités d'étalonnage		1: utilise unité métriques	2: utiliser unités américaines	

lb oz ne peuvent être sélectionnés comme unités d'étalonnage.

La balance ne nous laissera pas passer à l'étape suivante s'il y a une erreur lors de la programmation.

## TROISIÈME ÉTAPE

LF 2



- Appuyez sur la touche pour démarrer et cela affichera VALEUR INTERNE. Appuyez sur pour quitter le menu et la balance sera automatiquement réinitialisée.

262 144



- Appuyez sur pour continuer la configuration. (appuyez sur pour quitter la configuration et revenir au menu LF2).

10000 1



- Utilisez , et et pour sélectionner les UNITÉS ET LE MODE DE PESAGE selon le tableau ci-dessus. (appuyez sur pour quitter l'étalonnage et revenir au menu LF2).

000000kg



- Utilisez , et , et pour sélectionner CAPACITÉ MAXIMALE, en prenant en compte le nombre de décimales à sélectionner à l'étape suivante. (appuyez sur pour quitter l'étalonnage et revenir au menu LF2)

d 0.0kg



- Utilisez , et pour déplacer le point décimal. (appuyez sur pour quitter la configuration et revenir au menu LF2).

d.0 0 1



- Utilisez et pour changer l'échelon (appuyez sur pour quitter la configuration et revenir au menu LF2).

LF 2



- Utilisez , et pour continuer avec d'autres configurations ou appuyez sur pour quitter le menu et la balance sera automatiquement réinitialisée).

## VITESSE DU CONVERTISSEUR AD LF4













**SPEED 1** vitesse standard 15Hz.

**SPEED 2** vitesse élevée 30Hz.

**SPEED 3** vitesse basse 7.5Hz

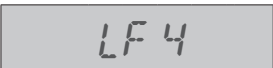











\*Cette fonction est bloquée lorsque UF-5 est en mode HOLD 1.

\*La valeur d'usine est 1.

ÉCRAN	DESCRIPTION ET SÉQUENCE D'UTILISATION
 	<ul style="list-style-type: none"> <li>Appuyez sur  pour démarrer ou sur  pour quitter le menu et la balance redémarrera automatiquement.</li> </ul>
 	<ul style="list-style-type: none"> <li>Utilisez  puis  pour sélectionner la vitesse du convertisseur AD (appuyez sur  pour quitter la configuration et revenir au menu LF4).</li> </ul>
	<ul style="list-style-type: none"> <li>Utilisez ,  et  pour continuer avec d'autres réglages ou appuyez sur  pour quitter le menu et la balance sera automatiquement réinitialisée.</li> </ul>

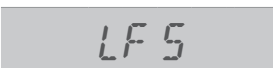
## AVEUGLE LF5

ÉCRAN	DESCRIPTION ET SÉQUENCE D'UTILISATION
	<p><b>ZP 0</b> OFF.</p> <p><b>ZP 1</b> Une division ne sera pas affichée en étant sur zéro.</p> <p><b>ZP 2</b> Deux divisions ne seront pas affichées en étant sur zéro.</p> <p><b>ZP 3</b> Trois divisions ne seront pas affichées en étant sur zéro.</p> <p><b>ZP 4</b> Quatre divisions ne seront pas affichées en étant sur zéro.</p> <p><b>ZP 5</b> Cinq divisions ne seront pas affichées en étant sur zéro.</p> <p>*Cette fonction est bloquée lorsque UF-5 est en mode HOLD 1.</p> <p>*La valeur d'usine est ZP 0.</p>

ÉCRAN	DESCRIPTION ET SÉQUENCE D'UTILISATION
 	<ul style="list-style-type: none"> <li>Appuyez sur  pour démarrer ou sur  pour quitter le menu et la balance redémarrera automatiquement.</li> </ul>
 	<ul style="list-style-type: none"> <li>Utilisez  et  pour sélectionner le nombre de divisions qui seront affichées sur zéro. (appuyez sur <b>ESC</b> pour quitter la configuration et revenir au menu LF4)</li> </ul>
	<ul style="list-style-type: none"> <li>Utilisez ,  et  pour continuer avec d'autres réglages ou appuyez sur  pour quitter le menu et la balance sera automatiquement réinitialisée.</li> </ul>

**CONFORMITÉ D'APPROBATION LF 6****DISPLAY**

0M LF 6

**DESCRIPTION ET SÉQUENCE D'UTILISATION**

**nonE** Version non vérifiée **OIML** version vérifiée  
**NE MODIFIER EN AUCUN CAS CE PARAMÈTRE.**

La modification de ce paramètre implique le blocage de certaines fonctionnalités.

**GRAVITÉ LF 7**

\*Entrez la gravité de votre région avant de réaliser le premier étalonnage.

\*Entrez la gravité de destination avant de réaliser l'étalonnage.

\*La valeur de la gravité sera refusée si supérieure à 9,83217 (gravité de pôle) ou inférieure à 9,78031 (gravité de l'Équateur).

Valeur d'usine: 9.801

**ÉCRAN**

LF 7



--00--

9.8035



9.8035

**DESCRIPTION ET SÉQUENCE D'UTILISATION**

• Appuyez sur pour continuer ou sur pour quitter le menu et la balance redémarrera automatiquement.

• L'écran affichera le nombre de pré-étalonnages pendant une seconde.

• Appuyez sur pour continuer.

• Utilisez , et , **0 ~ 9** et pour introduire la valeur de gravité. (appuyez sur ESC pour quitter la configuration et revenir au menu LF 7).

**ZÉRO INITIAL LF 8**

**SEIZ Y** remet à zéro le point zéro à chaque fois que la balance est réinitialisée

**SEIZ n** remet à zéro le point zéro OFF

**ÉCRAN**

LF 8



SeIZ Y



LF 8

**DESCRIPTION ET SÉQUENCE D'UTILISATION**

• Appuyez sur pour démarrer ou sur pour quitter le menu et la balance redémarrera automatiquement.

• Utilisez et et pour sélectionner le mode zéro initial. (appuyez sur pour quitter la configuration et revenir au menu LF8)

• Utilisez , et pour continuer avec d'autres réglages ou appuyez sur pour quitter le menu et la balance sera automatiquement réinitialisée.

## 11. MESSAGES D'ERREUR

MESSAGE	DESCRIPTION
	Point zéro trop élevé
	Point zéro trop élevé
	Point zéro trop élevé
	Point zéro trop bas
	Point zéro trop bas
	Le poids n'est pas stable
	Le code interne n'est pas stable
	Surcharge
	Surcharge
	Surcharge
	Correction de linéarité mal ou annulation de correction de linéarité
	Le poids est trop faible
	Le code interne est trop faible
	E2ROM anormal
	Le prix total est supérieur à 999999
	Le volume de la batterie est trop faible

## **12. GARANTIE**

Cet indicateur est garanti contre les défauts de fabrication et de matériaux pour une période de 1 an à compter de la date de livraison. Durant cette période, Giropès, se chargera de la réparation de l'indicateur. Cette garantie ne couvre pas les dommages causés par une mauvaise utilisation ou une surcharge. La garantie ne couvre pas les frais d'expédition (fret) nécessaires à la réparation de l'indicateur.

## 1. SPECIFICHE

### BR16

Precisione	Classe III
Intervallo di sensibilità della cella di carico	1,5 ~ 3,0 mV/V
Non linearità	0,01%F.S
Voltaggio cella	CC 5V
Gradino	1/2/5 (selezionabile)
Frequenza di campionamento	20 volte al secondo (al di fuori della metrologia)
Risoluzione interna	300.000-600.000

## 2. ALIMENTAZIONE

### BR16

Ingresso	100/240V CA
Uscita	12V/1A
Batteria ricaricabile	6V/4Ah

## 3. PRIMA DELL'USO

- 1) Situare la bilancia su una superficie piana e stabile, non esporla ad ambienti con vibrazioni.
- 2) Utilizzare una sorgente elettrica indipendente, evitare perturbazioni elettriche.
- 3) Durante l'avvio dell'indicatore, non collocare nessun oggetto sulla piattaforma.
- 4) Prima di utilizzare la bilancia, consentirne il preriscaldamento per 2-3 minuti.
- 5) Evitare bruschi cambi di temperatura e correnti d'aria.
- 6) Non sovraccaricare mai la bilancia né superare la capacità massima.

## 4. CONSUMO

- Consumo normale a riposo: 12mA - 333h ca.
- Consumo con la retroilluminazione: 36mA - 111,11h ca.
- Consumo con la retroilluminazione e uscita RS-232: 48mA-83h ca.
- Durata della batteria: senza la retroilluminazione, 320 ore ca.

## 5. COLLEGAMENTO DELLA CELLA DI CARICO ALL'INDICATORE

- 1) Il connettore della cella di carico è a 7 pin.
- 2) Quando l'indicatore è in funzione, non scollegare il connettore dalla cella di carico perché questo potrebbe danneggiare l'apparecchiatura.

**SCHEMA DELLA CELLA A 7 PIN**

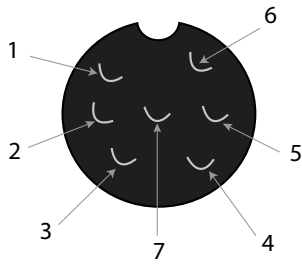
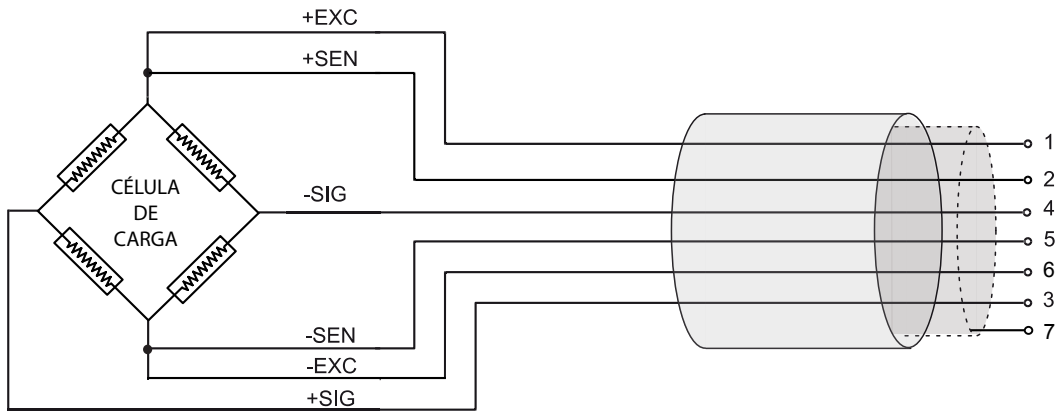

PIN 1	EXC +
PIN 2	SEN +
PIN 3	SIG +
PIN 4	SIG -
PIN 5	SEN -
PIN 6	EXC -
PIN 7	GND

**COLLEGAMENTO RS232**

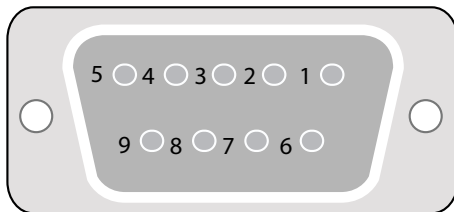

2	Tx
3	Rx
5	GND

**PROTOCOLLO**

UART signal of EIA-RS232 C

SEGNALE UART DI EIA-RS232 C	
Uscita serie	1200 / 2400 / 4800 / 9600 / 19200 / 34800 bps
Bit di dati	8 bits
BIT DI PARITÀ	No
Bit di stop	1 bit

**INFORMAZIONI INTESTAZIONI**

Intestazione 1 (2 BYTE)	Intestazione 2 (2 BYTE)
OL – Sovraccarico	
ST – Stabile	NT – Peso netto
US – INSTABILE	GS – Peso lordo

## 6. DESCRIZIONE DEL DISPLAY E DELLA TASTIERA

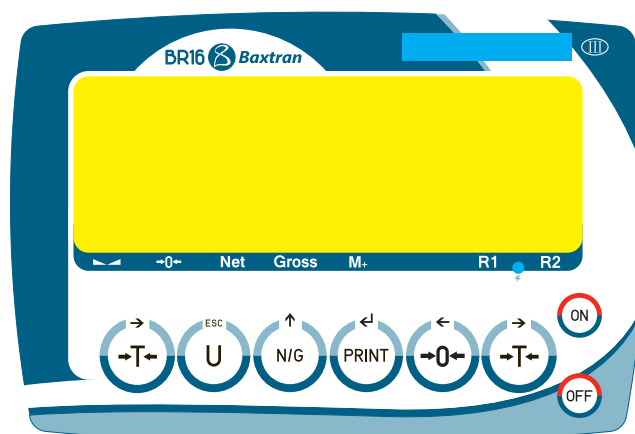

Per accendere la bilancia, premere questo tasto.



Per spegnere l'indicatore, mantenere premuto questo tasto per 2 secondi.



**1 funzione** Per cambiare l'unità di pesatura.

**2 funzione** Per uscire da un menu.

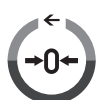

**1 funzione** Per mettere la lettura del display sullo zero "0", il valore del display deve essere inferiore a  $\pm 2\%$  della capacità massima.

**2 funzione** Per spostarsi di uno spazio verso sinistra o verso il basso in modalità di programmazione.



**1 funzione** Per sottrarre il peso di un contenitore.

**2 funzione** Per spostarsi di uno spazio verso destra o verso l'alto in modalità di programmazione.



**1 funzione** Per visualizzare il peso netto o lordo di un prodotto quando è stata realizzata una Tara. Quando si visualizza il peso lordo del prodotto, gli altri tasti sono disattivati.



**2 funzione** Per aumentare i valori in modalità di programmazione.





**1 funzione** Trasmissione manuale di dati mediante la porta RS-232 a un PC o una stampante e secondo la modalità scelta.

**2 funzione** Tasto di conferma in modalità di programmazione.

## 7. MODALITÀ CONTAPEZZI

1. Premere il tasto  affinché lo schermo non visualizza Pcs.
2. Premere  successivamente per selezionare la quantità di pezzi del campione. Lo schermo visualizzerà successivamente C 10 / C 20 / C 50 / C 100 / C 200.
3. Porre il campione sulla piattaforma, aspettare che si accenda l'indicatore di stabilità e premere il tasto .
4. Collocare il prodotto sopra la piattaforma e lo schermo visualizzerà il numero di pezzi.

L'accumulo e l'invio dei dati dipenderà dalla modalità scelta nel paragrafo [UF-6](#).

- Per tornare alla modalità di pesatura normale, premere il tasto .
- Per tornare alla modalità contapezzi, usando lo stesso campione di riferimento, premere nuovamente il tasto .
- Per modificare il campione di riferimento, ripetere i passaggi descritti precedentemente



## 8. CONFIGURAZIONE DEI PARAMETRI

8.1	CALCOLI INTERNI (A/D)	UF-1
8.2	CONFIGURAZIONE DEI LIMITI DI PESO (SUPERIORE E INFERIORE)	UF-2
8.3	DISATTIVAZIONE AUTOMATICA	UF-3
8.4	CONFIGURAZIONE DELL'ILLUMINAZIONE DEL DISPLAY	UF-4
8.5	FUNZIONE HOLD	UF-5
8.6	USCITA DEI DATI RS-232	UF-6
8.7	CONFIGURAZIONE DELLA VELOCITÀ RS-232	UF-7
8.8	MEDIA DELLO ZERO	UF-8
8.9	CONFIGURAZIONE DELLA GRAVITÀ	UF-9

Per accedere alla configurazione dei parametri, premere contemporaneamente i tasti e .

Premere i tasti e per navigare nel menu (UF-1 ~ UF-9).

Premere il tasto per accedere al parametro e confermare.

Premere il tasto per uscire dal menu e tornare alla modalità di pesatura.

### 8.1 CALCOLI INTERNI (A/D) | UF-1

1. Premere il tasto per visualizzare i calcoli interni della bilancia.
2. Per passare al parametro seguente, premere il tasto e lo schermo indicherà il voltaggio della batteria.
3. Premere il tasto per tornare al menu UF.





### 8.2 CONFIGURAZIONE DEI LIMITI DI PESO (SUPERIORE E INFERIORE) | UF-2

1. Premere il tasto per accedere al parametro.
2. Il display visualizzerà il messaggio "000000L" (Limite inferiore).
3. Utilizzare i tasti e per spostare il cursore e il tasto per selezionare il numero desiderato.
4. Premere il tasto per confermare.
5. Il display visualizzerà "00000H" (Limite superiore).
6. Utilizzare i tasti e per muovere il cursore e il tasto per selezionare il numero desiderato.
7. Premere il tasto per confermare.
8. Il display visualizzerà il valore

A B C  
0 0 0

(configurazione dell'allarme)



DISPLAY	VALOR	STABILITÀ
A	0	non serve stabilità per suonare
	1	serve stabilità per suonare
B	0	sempre 0
C	0	allarme spento
	1	1 l'allarme suona se è nella fascia Ok (tra i limiti <b>Ok</b> (límites Entre <b>Lo</b> y <b>Hi</b> )
	2	l'allarme suona se è sotto il limite inferiore <b>Lo</b> od oltre il limite superiore <b>Hi</b>





9. Utilizzare i tasti  e  per muovere il cursore e il tasto  per selezionare il numero desiderato.
10. Premere il tasto  per confermare.

Le indicazioni sullo schermo **Lo**, **Ok**, **Hi** appariranno sullo schermo secondo il peso.

### 8.3 DISATTIVAZIONE AUTOMATICA | UF-3



MODALITÀ:



	Disattivazione automatica disabilitata.
	Disattivazione automatica abilitata, la bilancia si spegnerà automaticamente dopo 1 minuto-senza essere utilizzata. Selezionare il tempo di disattivazione automatica tra 1 e 99 minuti.

1. Premere il tasto  per accedere al parametro.
2. Utilizzare i tasti  e  per spostare il cursore e il tasto  per selezionare il tempo desiderato.
3. Premere il tasto  per confermare.

### 8.4 CONFIGURAZIONE DELL'ILLUMINAZIONE DEL DISPLAY | UF-4



MODALITÀ:

	Automatica.
	Illuminazione sempre attivata.
	Illuminazione disattivata.

1. Premere il tasto  per accedere al parametro.
2. Premere il tasto  per selezionare la modalità desiderata.
3. Premere il tasto  per confermare.

### 8.5 FUNZIONE HOLD | UF-5









La modalità **HOLD** fa in modo che, una volta ritirato l'oggetto dal piatto, il display mantenga il peso fissato fino alla pressione di  (funzione , molto utile per la pesatura di animali). **Nota: se è attivata la modalità hold, NON SARÀ POSSIBILE UTILIZZARE LE FUNZIONI LIMITI O ACCUMULO.**

1. Premere il tasto  per accedere al parametro.
2. Premere il tasto  per selezionare la modalità desiderata.
3. Premere il tasto per  confermare.

## MODALITÀ:



- **HOLD 0** : Disattivata
- **HOLD 1** : Animale in movimento.
- **HOLD 2** : Valore di picco.
- **HOLD 3** : Hold stabile.
- **HOLD 4** : Hold stabile con autocancellazione a zero.

**HOLD 1.**

- Dopo aver acceduto a questo parametro, lo schermo visualizza **Pct**,
- Utilizzare i tasti  e  per spostare il cursore e il tasto  per selezionare il valore dell'intervallo di HOLD desiderato da 001 a 100.
- Premere il tasto  per confermare.
- Lo schermo visualizzerà **time 8**, utilizzare i tasti  e  per spostare il cursore e il tasto  per selezionare il numero di ripetizioni desiderato durante l'intervallo di hold.
- Premere il tasto  per confermare.

*Esempio: Pct piccolo e time grande implicano una precisione e un tempo di stabilizzazione maggiori.*

**8.6 USCITA DEI DATI RS-232 | UF-6**

1. Premere il tasto  per accedere al parametro.
2. Premere il tasto  per selezionare la velocità di trasmissione desiderata.
3. Premere il tasto  per confermare.

**FORMATO DEI DATI**

Nessun formato

**232 0** Uscita RS-232 Disattivata

**Formato 1 PC**

FORMATO AUTOMATICO DI PESO O PEZZI

ST,GS,+0003. 58 kg <CR><LF>

ST,GS,+0000250pcs <CR><LF>

**232 1** Invio di frame, senza accumulo, quando raggiunge la stabilità con **formato 1.**

**232 2** Invio di frame continuo con **formato 1.**

**232 3** Invio di frame, senza accumulo, manuale premendo il tasto  con **formato 1.**

**Formato 2 PC**

FORMATO AUTOMATICO DI PESO O PEZZI

+0000.64kg<CR><LF>

+0000100pcs<CR><LF>

**232 4** Invio di frame, senza accumulo, quando raggiunge la stabilità con **formato 2.**

**232 5** Invio di frame continuo con **formato 2.**

**232 6** Invio di frame, senza accumulo, manuale premendo il tasto  con **formato 2.**

**Formato 3 stampante**

FORMATO AUTOMATICO DI PESO O PEZZI

S/N	WT/kg	S/N	WT/pcs
0001	0.64	0001	20
0002	0.70	0002	21
0003	0.64	0003	45
-----		-----	
0003	1.98	0003	86

**232 7** Invio di frame e accumulo manuale, passando per zero e premendo il tasto  con **formato 3.**

0002 0.70

Con lo schermo a 0, se si preme due volte consecutive il tasto  si stampa la linea del totale.

-----  
0003 1.98

E si cancellano le pesature in memoria. .

INVIO DI FRAME

Nota: Accumulo e totale non disponibili per metrologia legale.

**232 8** Invio di frame e accumulo automatico alla stabilità, passando per 0 con **formato 3.**

0002 21

Con lo schermo a 0, se si preme due volte consecutive il tasto  si stampa la linea del totale.

-----  
0003 86

E si cancellano le pesature in memoria.

Nota: Accumulo e totale non disponibili per metrologia legale.

**Formato 4 stampante**

FORMATO AUTOMATICO  
DI PESO O PEZZI

TICKET NO.0003	
G	0.64kg
T	0.00kg
N	0.64kg
TOTAL NUMBER OF TICKETS 0003	
TOTAL	
NET	1.92

TICKET NO.0002	
G	20pcs
T	0pcs
N	20pcs
TOTAL NUMBER OF TICKETS 0002	
TOTAL	
NET	40

**N.B:** totale non disponibile in metrologia legale.



INVIO DI FRAME

**232 9**

Invio di frame e accumulo manuale, passando per zero e premendo il tasto  con **formato 4**

TICKET NO.0003	
G	0.64kg
T	0.00kg
N	0.64kg

Con lo schermo a 0, se si preme due volte consecutive il tasto si  stampa il riassunto degli scontrini.

Sulle nuove versioni è possibile che l'utente debba premere  e quando viene visualizzato il numero e il peso degli accumuli, premere  per stampare i valori e cancellare anche la memoria al stesso tempo.

TOTAL NUMBER OF TICKETS 0003	
TOTAL	
NET	1.92

E si cancellano le pesature in memoria.

**N.B:** totale non disponibile in metrologia legale.



INVIO DI FRAME

**232 10**

Invio di frame e accumulo automatico alla stabilità, passando per zero e premendo il tasto  con **formato 4.**

TICKET NO.0002	
G	20pcs
T	0pcs
N	20pcs

Con lo schermo a 0, se si preme due volte consecutive il tasto si  stampa il riassunto degli scontrini.

Sulle nuove versioni è possibile che l'utente debba premere  e quando viene visualizzato il numero e il peso degli accumuli, premere  per stampare i valori e cancellare anche la memoria al stesso tempo.

TOTAL NUMBER OF TICKETS 0003	
TOTAL	
NET	1.92

E si cancellano le pesature in memoria.

**N.B:** totale non disponibile in metrologia legale.

**N.B:** Ogni volta che viene effettuato un accumulo, lo schermo visualizza il totale accumulato per 3 secondi.

### FORMATO 1 (232 1 ~ 3):

18 BYTES ASCII PER LE UNITÀ kg, g, t, lb

1	2	,	1	2	,	1	2	3	4	5	6	7	8	1	2	CR	LF
Intestazione 1			Intestazione 2			Dati								Unità			

21 BYTES ASCII PER LE UNITÀ tl, T, lboz

1	2	,	1	2	,	1	2	3	4	5	6	7	8	9	1	2	3	4	CR	LF
Intestazione 1			Intestazione 2			Dati									Unità					

19 BYTES ASCII PER LE UNITÀ pcs

1	2	,	1	2	,	1	2	3	4	5	6	7	8	1	2	3	CR	LF
Intestazione 1			Intestazione 2			Dati								Unità				

### FORMATO 2 (232 4 ~ 6):

12 BYTES ASCII PER LE UNITÀ kg, g, t, lb

1	2	3	4	5	6	7	8	1	2	CR	LF
Dati								Unità			



15 BYTES ASCII PER LE UNITÀ tl, T, lboz

1	2	3	4	5	6	7	8	9	1	2	3	4	CR	LF
Dati									Unità					

13 BYTES ASCII PER LE UNITÀ pcs

1	2	3	4	5	6	7	8	1	2	3	CR	LF
Dati								Unità				

## 8.7 CONFIGURAZIONE DELLA VELOCITÀ DEL CONVERTITORE | UF-7 (\*)

1. Premere il tasto  per accedere al parametro.
2. Premere il tasto  per selezionare la modalità desiderata.

Modalità 1 Normale

Modalità 2 Rapida

Modalità 3 Lenta

3. Premere il tasto  per confermare.

## 8.8 CIECA ZERO | UF-8 (\*)

Mostra 0 sullo schermo fino ad arrivare alla seguente suddivisione selezionata. Inizia a mostrare i valori a partire da questa suddivisione.

Esempio:





bilancia con e=2g

cieca su 5 suddivisioni

Mostrerà 0 fino ad arrivare a 2x5=10g, il primo valore che mostrerà sarà 12g.

1. Premere il tasto  per accedere al parametro.
2. Premere il tasto  per selezionare.
3. Premere il tasto  per confermare.

## 8.9 CONFIGURAZIONE DELLA GRAVITÀ | *UF-9* (\*)

1. Premere il tasto  per accedere al parametro.
2. Per modificare il valore, premere il tasto , quindi utilizzare i tasti, utilizzare i tasti  e  per spostare il cursore e il tasto per selezionare il numero desiderato.

## 9. CALIBRAZIONE (SOLO PER IL PERSONALE AUTORIZZATO) (\*)



<b>9.1</b>	<b>CALIBRAZIONE DELLO ZERO + PESO (SPAN)</b>	<i>ECF-1</i>
<b>9.2</b>	<b>CALIBRAZIONE DELLO ZERO</b>	<i>ECF-2</i>
<b>9.3</b>	<b>CALIBRAZIONE DEL PESO (SPAN)</b>	<i>ECF-3</i>

0. Spostare lo switch interno su CAL ON.

1. Nella modalità normale di pesatura, premere i tasti  e , il display visualizzerà il messaggio **ECF-1**.
2. Premere i tasti  e  per selezionare la funzione desiderata: **ECF-1, ECF-2 o ECF-3**

### 9.1 CALIBRAZIONE DELLO ZERO + PESO | *ECF-1*

Premere il tasto , il display visualizzerà CALZ.

Premere il tasto , per azzerare la lettura del display.

Premere i tasti  e  per spostare il cursore.

Premere il tasto , per inserire il valore del peso di calibrazione.

Collocare il peso di calibrazione sulla piattaforma e premere il tasto  per effettuare la calibrazione quando la lettura sarà stabile.

### 9.2 CALIBRAZIONE DELLO ZERO | *ECF-2*

Premere il tasto , il display visualizzerà CALZ.

Premere il tasto , per azzerare la lettura del display.

Premere il tasto , per effettuare la calibrazione.

### 9.3 CALIBRAZIONE DEL PESO | *ECF-3*

Premere il tasto , il display visualizzerà il valore del peso di calibrazione.

Premere il tasto  e  per spostare il cursore.

Premere il tasto , per modificare il valore del peso di calibrazione.

Premere il tasto , per confermare.

Collocare il peso di calibrazione sulla piattaforma e premere il tasto  per effettuare la calibrazione quando la lettura sarà stabile.

## 10. PARAMETRI TECNICI



NON MODIFICARE I PARAMETRI TECNICI SE NON È STRETTAMENTE NECESSARIO. UNA ERRATA CONFIGURAZIONE DI QUESTA SEZIONE PUÒ PROVOCARE UN MALFUNZIONAMENTO DELLA BILANCIA.

In caso di schermi collaudati, aprire lo schermo e spostare l'interruttore di calibrazione nella posizione CAL ON. In tal caso, è opportuno ricordare che la rottura dei sigilli comporta la perdita del collaudo.

### ENTRARE E USCIRE DALLA CALIBRAZIONE

DISPLAY	DESCRIZIONE E SEQUENZA D'USO
	<ul style="list-style-type: none"> <li>• CON L'INTERRUTTORE INTERNO IN POSIZIONE CAL ON.</li> <li>• Con lo schermo spento, tenere premuto il tasto  e accensione di apparecchiatura; quando lo schermo mostra <b>100 t</b>, rilasciare il tasto .</li> </ul>
	<p>Premere il tasto  per accedere ai tasti  o  per cambiare parametro e il tasto per uscire dal  menu e lo schermo si riavvierà automaticamente.</p>

### CALIBRAZIONE DEL PESO *LF 1*

DISPLAY	DESCRIZIONE E SEQUENZA D'USO
	<p>La calibrazione può essere effettuata con qualsiasi peso, ma il peso non deve essere inferiore a 1/3 della capacità massima e quest'ultima non deve essere mai superata.</p>
	<ul style="list-style-type: none"> <li>• Premere il tasto  per iniziare la calibrazione dello zero (premere  per uscire dalla calibrazione e tornare al men LF1)</li> </ul>
	<ul style="list-style-type: none"> <li>• Utilizzare ,  e , <b>0 ~ 9</b> e quindi  per inserire il peso con cui verrà effettuata la calibrazione. (Premere  per uscire dalla calibrazione e tornare al menu LF1)</li> </ul>
	<ul style="list-style-type: none"> <li>• Collocare il peso richiesto sulla bilancia nel modo indicato sul display lampeggiante.</li> </ul>
	<ul style="list-style-type: none"> <li>• Una volta stabilizzato, premere  per calibrarla. (premere ESC per uscire dalla calibrazione e tornare al menu LF1).</li> </ul>
	<p>LA CALIBRAZIONE TERMINERÀ E LA BASCULA TORNERÀ AUTOMATICAMENTE ALLA MODALITÀ DI PESATURA.</p>



## CONFIGURAZIONE LF2

### DISPLAY

### DESCRIZIONE E SEQUENZA D'USO

#### PRIMO PASSAGGIO

262 144

#### SECONDO PASSAGGIO

1 0 0 0 0 1

A B C D E F

- VISUALIZZAZIONE DEI CALCOLI INTERNI
- POSSIBILI VALORI DEI PARAMETRI DI CONFIGURAZIONE

A: Sistema metrico	0:NO	1: kg	2:T	3:g
B: Sistema americano	0:NO	1: lb	2:lb oz	
C: Altre unità	0:NO	1: TW kg	2:HK kg	3:VISS
D: PCS	0:OFF	1: ON		
E: Doppio range	0:OFF	1: multi intervallo	2:multi range	
F: Unità di calibrazione		1: usare unità metriche	2: usare unità americane	

lb oz non si possono selezionare come unità di calibrazione.

Se c'è un errore di programmazione, la bilancia non ci consentirà di andare al passaggio seguente.

#### TERZO PASSAGGIO

LF2



262 144



10000 1



000000kg



d 0.0kg



d 0 0 1



LF2



Dopo avere inserito i parametri LF2, lo schermo visualizzerà l'ultima configurazione salvata. Tutti i passaggi devono essere completati; in caso contrario, lo schermo continuerà con la configurazione precedente. Procedere con la calibrazione del peso dopo LF2.

- Premere il tasto per iniziare e lo schermo visualizzerà il VALORE INTERNO. Premere per uscire dal menu e la bilancia si riavvierà automaticamente.

- Premere il tasto per continuare con la configurazione. (premere per uscire dalla configurazione e tornare al menu LF2).

- Utilizzare , e , e quindi per selezionare le UNITÀ e la MODALITÀ DI PESATURA secondo la tabella precedente. (premere per uscire dalla calibrazione e tornare al menu LF2).

- Utilizzare , e , e quindi per selezionare la CAPACITÀ MASSIMA, tenendo in considerazione il numero di decimali che si selezionerà nel passaggio seguente. (premere per uscire dalla calibrazione e tornare al menu LF2).

- Utilizzare , e quindi per spostare il punto decimale. (premere per uscire dalla configurazione e tornare al menu LF2).

- Utilizzare e quindi per cambiare il gradino (premere per uscire dalla configurazione e tornare al menu LF2).

- Utilizzare , e per continuare con altre configurazioni o premere per uscire dal menu e la bilancia si riavvierà automaticamente.

**VELOCITÀ DEL CONVERTITORE AD LF 4**















**SPEED 1** velocità standard 15Hz.

**SPEED 2** alta velocità 30Hz.

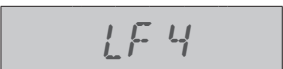











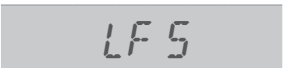



**SPEED 3** bassa velocità 7.5Hz

\*Questa funzione rimane bloccata quando UF-5 è in modalità HOLD 1.

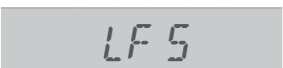
\*Il valore di fabbrica 1

DISPLAY	DESCRIZIONE E SEQUENZA D'USO
 	• Premere  per iniziare o  per uscire dal menu e la bascula si riavvierà automaticamente.
 	• Premere  e quindi  per selezionare la velocità del convertitore AD (premere  per uscire dalla configurazione e tornare al menu LF4).
 	• Premere  ,  e quindi  per continuare con altre regolazioni o premere  per uscire dal menu e la bascula si riavvierà automaticamente.

**CIECA LF 5**

DISPLAY	DESCRIZIONE E SEQUENZA D'USO
 	<p><b>ZP 0</b> OFF</p> <p><b>ZP 1</b> Una suddivisione non verrà mostrata quando è a zero</p> <p><b>ZP 2</b> Due suddivisioni non verranno mostrate quando è a zero</p> <p><b>ZP 3</b> Tre suddivisioni non verranno mostrate quando è a zero</p> <p><b>ZP 4</b> Quattro suddivisioni non verranno mostrate quando è a zero</p> <p><b>ZP 5</b> Cinque suddivisioni non verranno mostrate quando è a zero</p> <p>*Questa funzione rimane bloccata quando UF-5 è in modalità HOLD 1</p> <p>*Il valore di fabbrica è ZP 0</p>
 	• Premere  per iniziare o  per uscire dal menu e la bascula si riavvierà automaticamente.
 	• Utilizzare  e quindi  per selezionare le suddivisioni che non verranno mostrate a zero. premere <b>ESC</b> per uscire dalla configurazione e tornare al menu LF4)
 	• Utilizzare  ,  e quindi  per continuare con altre regolazioni o premere  per uscire dal menu e la bascula si riavvierà automaticamente.

## CONFORMITÀ DI APPROVAZIONE *LF 6*

### DISPLAY



### DESCRIZIONE E SEQUENZA D'USO

**nonE** Versione non verificata **OIML** versione verificata  
**NON MODIFICARE PER NESSUN MOTIVO QUESTO PARAMETRO.**  
 La modifica di questo parametro implica il blocco di alcune funzionalità.

## GRAVITÀ *LF 7*

\*Prima di effettuare la prima calibrazione, inserire la gravità della propria zona.

\*Dopo aver effettuato la calibrazione, inserire la gravità di destinazione.

\*Il valore della gravità sarà rifiutato se è maggiore di 9.83217 (gravità del polo) o minore di 9.78031 (gravità dell'equatore). Valore di fabbrica: 9.801

### DISPLAY

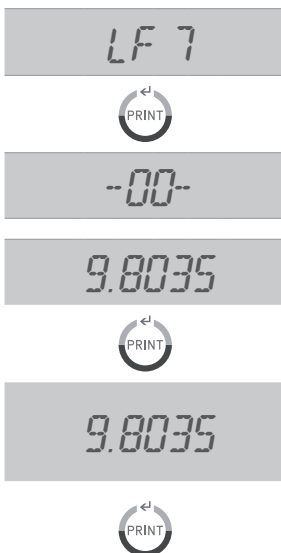

### DESCRIPCIÓN Y SECUENCIA DE USO

- Premere per continuare o per uscire dal menu e la bilancia si riavvierà automaticamente
- Lo schermo mostrerà il numero di precalibrazione per un secondo.
- Premere per continuare.
- Utilizzare , e , **0 ~ 9** e quindi per inserire il valore della gravità (premere ESC per uscire dalla configurazione e tornare al menu LF 7).

## ZERO INIZIALE *LF 8*

**SEIZ Y** resetta il punto dello zero ogni volta che si riavvia la bilancia

**SEIZ n** reset del punto zero OFF

### DISPLAY



### DESCRIZIONE E SEQUENZA D'USO

- Premere per iniziare o per uscire dal menu e la bilancia si riavvierà automaticamente
- Utilizzare e quindi per selezionare la modalità dello zero iniziale (premere per uscire dalla configurazione e tornare al menu LF8)
- Utilizzare , e quindi per continuare con altre regolazioni o premere per uscire dal menu e la bilancia si riavvierà automaticamente.

## 11. MESSAGGI DI ERRORE

MESSAGGI	DESCRIZIONE
	Punto zero troppo alto
	Punto zero troppo alto
	Punto zero troppo alto
	Punto zero troppo basso
	Punto zero troppo basso
	Il peso non è stabile
	Il codice interno non è stabile
	Sovraccarico
	Sovraccarico
	Sovraccarico
	La correzione della linearità non è corretta o la correzione della linearità si annulla
	Il peso è troppo basso
	Il codice interno è troppo basso
	E2ROM anormale.
	Il prezzo totale è superiore a 999999
	Il volume della batteria è troppo basso

## **12. GARANZIA**

Questo indicatore è protetto da una garanzia contro qualsiasi difetto di fabbricazione e di materiali della durata di un anno a partire dalla data di consegna. Durante questo periodo, GIROPÈS SL si farà carico della riparazione dello stesso.

Questa garanzia non include i danni causati da uso improprio o sovraccarichi.

La garanzia non copre le spese di spedizione (trasporto) necessarie alla riparazione dell'indicatore.

# 1. SPECIFICATIONS

## BR16

Precision	Clase III
Load Cell Sensitivity Range	1.5 ~ 3.0mV/V
Nonlinearity	≤0.01%F.S
Voltage cell	DC 5V
Step	1/2/5 (selectable)
Frequency of sampling	20 times per second (outside meteorology)
Internal resolution	300.000~600.000

# 2. EXCITATION

## BR16

Input	230~240V
Output	10V 600mA
Rechargeable Battery	6V/4Ah

# 3. BEFORE ITS USE

1. Use an independent electric source to prevent electronic disturbances.
2. Don't place any object on the platform when switching on the indicator.
3. Please, warm-up the scale during 2-3 minutes before using it.
4. Avoid sudden changes in temperature and draughts.
5. Don't overload the scale; do not exceed its maximum capacity.

# 4. CONSUMPTION

- Normal consumption at rest: approx. 12mA - 333h
- Consumption with backlight: aprox. 36mA - 111,11h
- Consumption with backlight and output RS-232: aprox. 48mA-83h
- Battery duration: without backlight, aprox. 320 h

# 5. CONNECTING THE CHARGING CELL TO THE INDICATOR

- 1) The connector of the load cell is 7 pins.
- 2) When the indicator is working, do not remove the connector from the load cell, this act could damage the equipment.

## 7 PIN CELL SCHEME

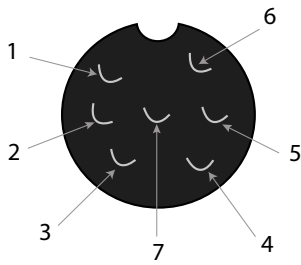
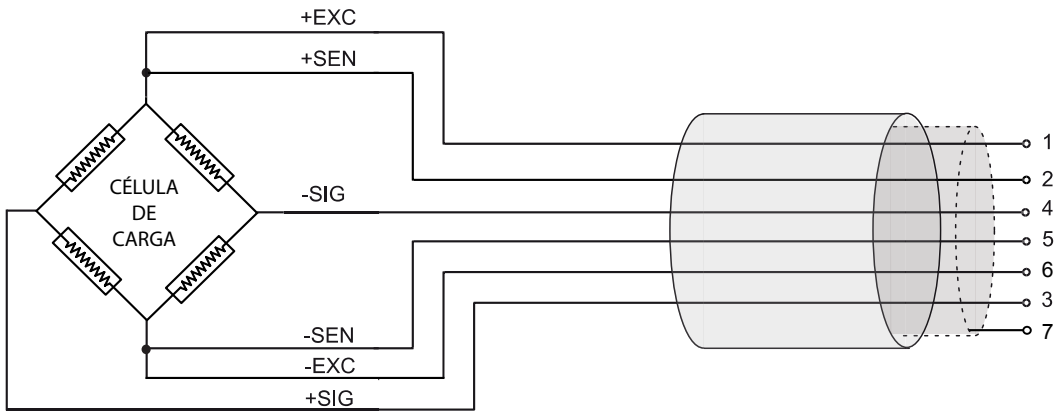

PIN 1	EXC +
PIN 2	SEN +
PIN 3	SIG +
PIN 4	SIG -
PIN 5	SEN -
PIN 6	EXC -
PIN 7	GND

## CONNECTION RS232

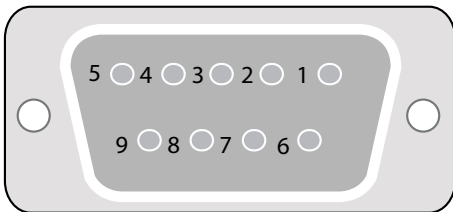

2	Tx
3	Rx
5	GND

## PROTOCOL

UART signal of EIA-RS232 C

SIGNAL UART EIA-RS232 C	
Serial output	1200 / 2400 / 4800 / 9600 / 19200 / 34800 bps
Data Bits	8 bits
Parity bits	No
STOP BITS	1 bit

### HEAD INFORMATION

HEAD 1 (2 BYTES)	HEAD 2 (2 BYTES)
OL – Extracharge	
ST – Stable	NT – Net weight
US – Unstable	GS – Net weight

## 6. KEYBOARD DESCRIPTION

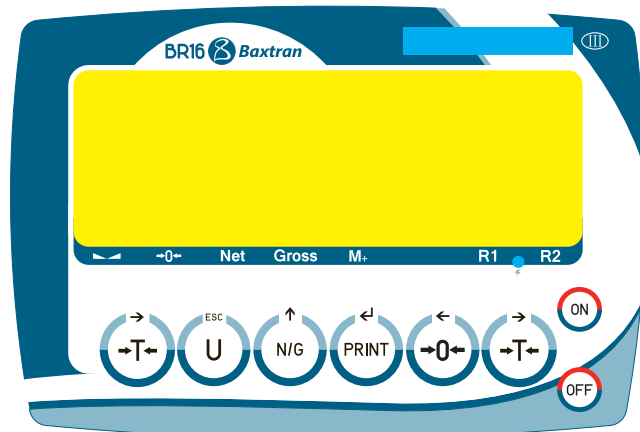

Press this key to turn on the balance.



Press and hold this key for 2 seconds to turn off the indicator.



**1<sup>o</sup> function** To change the weighing unit.

**2<sup>o</sup> function** To exit a menu.



**1<sup>o</sup> function** To set the display reading to zero "0", the display value must be less than  $\pm 2\%$  of the maximum capacity.

**2<sup>o</sup> function** To move a space to the left or down into the programming mode.



**1<sup>o</sup> function** To subtract the weight of a container.

**2<sup>o</sup> function** To move a space to the right or up in the programming mode.



**1<sup>o</sup> function** To display the net or gross weight of a product when a tare has been made. When the gross weight of the product is displayed the other keys are disabled.

**2<sup>o</sup> function** To increase the values within the programming mode.





**1<sup>o</sup> function** Manual transmission of data through the RS-232 port to a PC or printer and according to chosen mode.

**2<sup>o</sup> function** Confirmation key in programming mode.



## 7. PIECE COUNTING MODE

1. Press the key  until the symbol **PCS** appears on the screen
2. Press the key  successively to choose the quantity of pieces of the sample. On the screen will appear, successively, C10/C20/C50/C100/C200.
3. Place the sample on the platform, and wait until the sign of stability and press the key .
4. Place the product on the platform and the screen will show the number of pieces.



The accumulation and the sending of data will depend on the mode chosen in the section UF-6.

- To turn to the normal weighing mode, press the key .
- If the user wants to go back to the piece counting mode, using the same sample of reference, press the key  again.
- If the user want to change the sample of reference, the user must repeat the steps described above.

## 8. PARAMETERS CONFIGURATION

<b>8.1</b>	<b>INTERNAL COUNTING (A/D)</b>	<i>UF-1</i>
<b>8.2</b>	<b>CONFIGURATION OF THE WEIGHT LIMITS (SUPERIOR AND INFERIOR)</b>	<i>UF-2</i>
<b>8.3</b>	<b>AUTO SWITCH OFF</b>	<i>UF-3</i>
<b>8.4</b>	<b>CONFIGURATION OF THE ILLUMINATION OF THE DISPLAY</b>	<i>UF-4</i>
<b>8.5</b>	<b>HOLD FUNCTION</b>	<i>UF-5</i>
<b>8.6</b>	<b>RS-232 DATA EXIT</b>	<i>UF-6</i>
<b>8.7</b>	<b>CONFIGURATION OF THE SPEED OF THE AD CONVERTER</b>	<i>UF-7</i>
<b>8.8</b>	<b>BLIND</b>	<i>UF-8</i>
<b>8.9</b>	<b>CONFIGURATION OF THE GRAVITY</b>	<i>UF-9</i>



To access the configuration of parameters when the screen is in zero, the user must press at the same time the keys  and .

Press the key  or  to choose the desired character (UF-1 ~ UF-11).

Press the key  to access the parameter and confirm







To go back to the previous mode press the key .

### 8.1 INTERNAL COUNTING (A/D) | *UF-1*

1. Press the key  to view the internal sums of the scale.
2. To go to the next parameter, press the key  the screen will show the value of the voltage of the battery.
3. Press the key  to return to the menu *UF*.

### 8.2 CONFIGURATION OF THE LIMITS OF WEIGHT ( SUPERIOR AND INGERIOR) | *UF-2*

1. Press the key  to access the parameter.
2. The display will show the message " 000.00L" ( inferior limit)

3. Use the keys  and  to move the cursor and the key  to choose the desired number..
4. Press the key  to confirm.
5. The display will show the message "000.00h" (Superior limit=**Hi**)
6. Use the keys  and  to move the cursor and the key  to choose the desired number.

Note: If you need to change or modify the last digit you can place the cursor on it to do it.





7. Press the key  to confirm.
8. The display will show the value.

A	B	C
0	0	0

  
 (configuration of the alarm)

DISPLAY	VALUE	ESTABILITY
A	0	There is no need to stabilize the alarm to make it ring
	1	The alarm must be stabilized to ring
B	0	Always 0
C	0	Alarm switched off
	1	The alarm ring if it is place on the band <b>OK</b> ( between the limits <b>Lo</b> and <b>Hi</b> )
	2	The alarm rings if it is situated below the inferior limit <b>Lo</b> or above the superior limit <b>Hi</b>







9. Press the keys  and  to move the cursor and the key  to choose the desired number..
10. Press the key  to confirm.

The indications on screen **Lo**, **Ok**, **Hi** will appear on screen depending on the weight.

### 8.3 AUTO SWITCH OFF | UF-3

MODES:



- **AoFF 00** – Auto switch off deactivated
- **AoFF 01** – Auto switch off activated in a minute. The scale is going to switch off automatically after 1 minute of not being used.
- You can configure the value wished from 1 to 99 minutes.

1. Press the key  to have an access to the parameter.
2. Press the keys  and  to move the cursor and the key  to choose the desired number.
3. Press the key  to confirm.

### 8.4 DISPLAY BACKLIGHTING | UF-4



MODES:

- **A**: Automatic.
- **ON**: Illumination Activated.
- **OFF**: Illumination Deactivated.

1. Press the key  to have an access to the parameter.
2. Press the key  to select the desired mode.
3. Press the key  to confirm.

### 8.5 HOLD FUNCTION | UF-5









(Once the object is retired from the plate, the display maintains the weight fixed during some seconds. This function is very useful for the weighing of animals)

1. Press the key  to access to the parameter.
2. Press the key  to choose the desired mode.
3. Press the key  to confirm.



**MODES:**

- **HOLD 0** : Deactivated.
- **HOLD 1** : Animal in movement
- **HOLD 2** : Value of peak
- **HOLD 3** : Hold steady
- **HOLD 4** : Hold steady with self cancelling at zero.





**HOLD 1.**

- When the user can access this parameter, the screen shows the message **Pct**,
- Use the keys  and  to move the cursor and the key  to choose the desired value of the range of HOLD, you can choose a number from 001 to 100.
- Press the key  to confirm.
- It will appear on the screen the message **time 8**, use the keys  and  to move the cursor and the key  to choose the number of times you want to repeat during the range of hold.
- Press the key  to confirm. *Example: Pct small and big time means more accuracy and longer stabilization.*

## 8.6 RS-232 DATA EXIT | UF-6

1. Press the key  to access to the parameter.
2. Press the key  to select the transmission speed desired.
3. Press the key  to confirm.

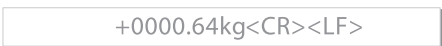
**232 0 EXIT RS-232 DEACTIVATED**

<b>FORMAT OF THE DATA</b>	
<b>Format 1 PC</b>	
VARIOUS FORMATS AVAILABLE	
	
CONNECTION SENDING	<b>232 1</b> Connection sending, without accumulation, when it achieves an estabily with <b>format 1</b>
	<b>232 2</b> Continuous connection sending with <b>format 1</b>
	<b>232 3</b> Connection sending, without accumulation, manual by pressing the key  with <b>format 1</b>
<b>Formato 2 PC</b>	
VARIOUS FORMATS AVAILABLE	
	
CONNECTION SENDING	<b>232 4</b> Connection sending, without accumulation, when it achieves the stability with <b>formato 2</b>
	<b>232 5</b> Continuous connection sending with <b>formato 2</b>
	<b>232 6</b> Connection sending, without accumulation, manual by pressing the key  with <b>format 2</b>

**Format 3 printer**

**DIFFERENT POSSIBLE FORMATS**

S/N	WT/kg	S/N	WT/pcs
0001	0.64	0001	20
0002	0.70	0002	21
0003	0.64	0003	45
-----		-----	
0003	1.98	0003	86

**232 7**

Connection sending and manual accumulation, passing by zero and pressing the key  with **format 3**.

0002	0.70
------	------

If the user presses the key  twice one after the other when the screen is in 0, the total line is printed

-----	
0003	1.98

And the memory of the weights is removed

**232 8**

Connection sending and automatic accumulation to stability, passing 0 with **format 3**.

If the user presses the key  twice one after the other when the screen is in 0, the total line is printed.

-----	
0003	1.98

And the memory of the weights is removed

**Format 4 printer**

**DIFFERENT POSSIBLE FORMATS**

TICKET NO.0003	TICKET NO.0002
G 0.64kg	G 20pcs
T 0.00kg	T 0pcs
N 0.64kg	N 20pcs
TOTAL NUMBER OF TICKETS 0003	TOTAL NUMBER OF TICKETS 0002
TOTAL	TOTAL
NET 1.92	NET 40

**232 9**

Connection sending and manual accumulation, passing 0 and pressing the key  with **format 4**.

TICKET N	O.0003
G	0.64kg
T	0.00kg
N	0.64kg



**232 10**

Connection sending and automatic accumulation to stability, passing 0 and pressing the key  with **format 4**.

TICKET NO.0003
G 0.64kg
T 0.00kg
N 0.64kg

If the user presses the key  twice one after the other when the screen is in 0, the summarizing of the tickets is printed.

TOTAL NUMBER OF TICKETS 0003	
TOTAL	
NET	1.92



On new Versions, it is possible that user have to press  and when showing the number and weight of accumulations, press  for print the values and also delete the memory at the same time.

And the memory of weights is removed

**NOTE:** Totalization not available in legal metrology.

If the user presses the key  twice one after the other when the screen is in 0, the summarizing of the tickets is printed. And the memory of weights is removed.

TOTAL NUMBER OF TICKETS 0003	
TOTAL	
NET	1.92

On new Versions, its is possible that user have to press  and when showing the number and weight of accumulations, press  for print the values and also delete the memory at the same time.

And the memory of weights is removed

**NOTE:** Totalization not available in legal metrology.

### FORMAT 1 (232 1 ~ 3):

18 BYTES ASCII FOR THE UNITIES kg, g, t, lb

1	2	,	1	2	,	1	2	3	4	5	6	7	8	1	2	CR	LF
Headboard 1			Headboard 2			data								Unit			

21 BYTES ASCII FOR THE UNITIES tl, T, lboz

1	2	,	1	2	,	1	2	3	4	5	6	7	8	9	1	2	3	4	CR	LF
Headboard 1			Headboard 2			data									Unit					

19 BYTES ASCII FOR THE UNIT pcs

1	2	,	1	2	,	1	2	3	4	5	6	7	8	1	2	3	CR	LF
Headboard 1			Headboard 2			data								Unit				

### FORMAT 2 (232 4 ~ 6):

12 BYTES ASCII FOR THE UNITIES kg, g, t, lb

1	2	3	4	5	6	7	8	1	2	CR	LF
data								Unit			

15 BYTES ASCII FOR THE UNITIES tl, T, lboz

1	2	3	4	5	6	7	8	9	1	2	3	4	CR	LF
data									Unit					

13 BYTES ASCII FOR THE UNIT pcs

1	2	3	4	5	6	7	8	1	2	3	CR	LF
data								Unit				

## 8.7 CONFIGURATION OF THE SPEED OF THE CONVERTER | UF--7

1. Press the key  to access the parameter.

2. Press the key  to choose the desired mode:

- Mode 1 : Normal
- Mode 2: Fast
- Mode 3: Slow

3. Press the key  to confirm.

## 8.8 BLIND | UF--8

It appears 0 on screen until the next division is selected. It starts to show values from that division.

Example:

Scale with  $e = 2g$

Blind in 5 divisions

It will show 0 until it reaches  $25 = 10g$ , the first value it will show will be 12g.

1. Press the key  to access the parameter.

2. Press the key  to select.

3. Press the key  to confirm.

## 8.9 CONFIGURATION OF GRAVITY | UF--9







1. Press the key  to view the value of the actual gravity.

2. To change the value, press the key , next you must use the key  and  to move the cursor and the key to select the desired number.



## 9. CONFIGURATION OF THE READJUSTMENTS IN CALIBRATION

- When the user is in the normal mode of weighing, he must press the keys  and  the message **ECF-1** is going to appear on the display.
- Press the keys  or  to select the desired function: **ECF-1, ECF-2 or ECF-3**







### \* ECF-1 CALIBRATION OF ZERO + WEIGHT

- Press the key , the display will show CALZ.
- Press the key , to put the reading of the display to zero.
- Press the keys  and  to move the cursor.
- Press the key , to introduce the value of the weight of calibration.
- Place the weight of calibration on the platform and press the key  to do the calibration once the reading is steady.

### \* ECF-2 CALIBRATION OF ZERO

- Press the key , the display will show CALZ.
- Press the key , to put the reading of the display to zero.
- Press the key , to calibration.

### \* CALIBRATION OF WEIGHT (SPAN)

- Press the key , the display will show the value of the weight of calibration.
- Press the keys  and  to move the cursor.
- Press the key , to modify the value of the weight of calibration.
- Press the key , to confirm.
- Place the weight of calibration on the platform and press the key  to do the calibration once the reading is stable.

## 10. TECHNICAL PARAMETERS

DO NOT MODIFY THE TECHNICAL PARAMETERS IF IT IS NOT STRICTLY NEEDED. A BAD CONFIGURATION OF THIS SECTION CAN CAUSE A WRONG FUNCTIONING OF THE SCALE.

### ENTRANCE AND EXIT OF THE CALIBRATION





#### DISPLAY

#### DESCRIPTION AND SEQUENCE OF USE

- WITH THE INTERNAL SWITCH IN THE CAL ON POSITION.

LF 1

- With the display off, press and hold the key  and power on, when the display shows *100 1* release the key .

- Press the key  to access the keys  and  to change the parameter, and the key  to exit the menu and the display will restart automatically.

## CALIBRATION OF THE WEIGHT LF 1

DISPLAY	DESCRIPTION AND SEQUENCE OF USE
LF 1	<p>✘ The calibration can be done with any weight, but the weight ca not be inferior to 1/100 of the maximum capacity and it must also never be exceeded.</p> <ul style="list-style-type: none"> <li>• Press the key  to start the calibration of zero ( press  To exit the calibration and go back to the menu LF1)</li> <li>• Use ,  and , 0 ~ 9 and then press  to introduce the weight with which the calibration will be done. ( press the key  to exit the calibration and go back to the menu LF1)</li> <li>• Place the required weight on the scale as it is indicated in the display.</li> <li>• Once everything is steady, press the key  to calibrate it ( press the key ESC to exit the calibration and go back to the menu LF1).</li> </ul> <p>THE CALIBRATION IS GOING TO FINISH AND THE SCALE WILL GO VACK TO THE WEIGHING MODE AUTOMATICALLY.</p>
CAL 2	
150.00 kg	
150.00 kg	
150.00 kg	
150.00 kg	

## CONFIGURATION LF 2

DISPLAY	DESCRIPTION AND SEQUENCE OF USE																														
<b>FIRST STEP</b>	<ul style="list-style-type: none"> <li>• DISPLAY OF THE INTERNAL COUNTING</li> <li>• POSSIBLE VALUES OF THE PARAMETERS</li> </ul> <table border="1"> <tr> <td>A: Metric system</td> <td>0:NO</td> <td>1: kg</td> <td>2:T</td> <td>3:g</td> </tr> <tr> <td>B: American system</td> <td>0:NO</td> <td>1: lb</td> <td>2:lb oz</td> <td></td> </tr> <tr> <td>C: other unities</td> <td>0:NO</td> <td>1: TW kg</td> <td>2:HK kg</td> <td>3:VISS</td> </tr> <tr> <td>D: PCS</td> <td>0:OFF</td> <td>1: ON</td> <td></td> <td></td> </tr> <tr> <td>E: double range</td> <td>0:OFF</td> <td>1: multi interval</td> <td>2:multi range</td> <td></td> </tr> <tr> <td>F: units of calibration</td> <td></td> <td>1:use metric unities</td> <td>2:use american unities</td> <td></td> </tr> </table> <p>✘ lb oz cannot be selected as unities of calibration.</p> <p>✘ The scale won't let us continue up to the next step if there is a mistake during the programming.</p>	A: Metric system	0:NO	1: kg	2:T	3:g	B: American system	0:NO	1: lb	2:lb oz		C: other unities	0:NO	1: TW kg	2:HK kg	3:VISS	D: PCS	0:OFF	1: ON			E: double range	0:OFF	1: multi interval	2:multi range		F: units of calibration		1:use metric unities	2:use american unities	
A: Metric system		0:NO	1: kg	2:T	3:g																										
B: American system		0:NO	1: lb	2:lb oz																											
C: other unities		0:NO	1: TW kg	2:HK kg	3:VISS																										
D: PCS		0:OFF	1: ON																												
E: double range		0:OFF	1: multi interval	2:multi range																											
F: units of calibration		1:use metric unities	2:use american unities																												
262 144																															
<b>SECOND STEP</b>																															
1 0 0 0 0 1																															
A B C D E F																															
<b>THIRD STEP</b>																															
000000kg																															
<b>FOURTH STEP</b>																															
dP 0.0																															
<b>FIFTH STEP</b>																															
dV 0 1																															
	<ul style="list-style-type: none"> <li>• Use ,  and , 0 ~ 9 and then press  to introduce THE MAXIMUM CAPACITY, considering the number of decimal zeros to be used. Ex. 150.00kg = introduce 15000 if then selected as decimal <i>d0.00</i></li> <li>• Use the Keys ,  to change the position of the DECIMAL POINT.</li> </ul> <table border="1"> <tr> <td>d 0.00</td> <td>d 0.000</td> <td>d 0.0000</td> <td>0.00000</td> </tr> </table> <ul style="list-style-type: none"> <li>• Use  to select the DIVISION:  <i>dV 0 1, dV 02, dV 05, dV 10, dV 20, dV 50</i></li> </ul>	d 0.00	d 0.000	d 0.0000	0.00000																										
d 0.00	d 0.000	d 0.0000	0.00000																												



✘ After introducing the parameters LF2, the indicator will show the last configuration saved. All the steps to follow must be completed, if they are not done the indicator will continue with the previous configuration.

✘ Proceed with the calibration of weight after LF2.

LF 2



• Press the key to start and display the internal value. Press to exit the menu and the scale will automatically restart.

262 144



• Press the key to continue with the configuration. (press the key to exit from the configuration and go back to the menu LF2).

10000 1



• Use the keys , and , 0 ~ 9 and then press the key to choose the UNITS OF WEIGHT . (press the key to exit from the configuration and go back to the menu LF2).

000000kg



• Use the keys , and , 0 ~ 9 and then press the key to choose the MAXIMUM WEIGHT. press the key to exit from the configuration and go back to the menu LF2).

d 0.0kg



• Use the keys , and Then To move the decimal point ( press the key To exit from the configuration and go back to the menu LF2).

d.v 0 1



• Use and then to change the step. (Press the key To exit from the configuration and go back to the menu LF2).

LF2



• Use , and then To continue with the other configuration or press the key to exit from the menu and the scale will begin again automatically).

## SPEED OF THE AD CONVERTER LF 4

**SPEED 1** standard speed 15Hz.

**SPEED 2** high speed 30Hz.

**SPEED 3** low speed 7.5Hz



\*This function stays blocked when UF-5 is in mode HOLD 1.



\*The value of factory is 1





DISPLAY

DESCRIPTION AND SEQUENCE OF USE



• Press the key  to start or the key  to exit from the menu and the scale is going to begin again automatically.

• Use the key  and then the key  to select the speed of the AD converter ( press the key  to exit from the configuration and go back to the menu LF4)

• Use the keys ,  and then the key  To continue with the other adjustment and press the key  to exit from the menu and the scale will start again automatically.

## BLINF LF 5

### DISPLAY

### DESCRIPTION AND SEQUENCE OF USE

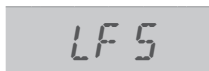

**ZP 0** OFF

**ZP 1** One division will not show being at zero

**ZP 2** Two division will not show being at zero

**ZP 3** Three divisions will not show being at zero

**ZP 4** Four divisions will not show being at zero

**ZP 5** Five divisions will not show being at zero

\*This function is going to be blocked when UF-5 is in mode HOLD 1

\*The value of factory is ZP 0



### DISPLAY

### DESCRIPTION AND SEQUENCE OF USE



• Press the key  to start or the key  to exit from the menu and the scale will start again automatically.



• Use the key  and the key  to select how many divisions will show when in zero ( press **ESC** to exit from the configuration and go back to the menu LF4)



• Use the keys ,  and then the key  to continue with other adjustment or press the key  to exit from the menu and the scale is going to start automatically.

## APPROVAL CONFIRMITY LF 6

### DISPLAY

### DESCRIPTION AND SEQUENCE OF USE



**nonE** Version not approved

**DON'T MODIFY, IN NO WAY, THIS PARAMETER. IT MUST ALWAYS BE CONFIGURED AT**

**nonE.**

The change of this parameter implies the blocking of some functionalities.

















**GRAVITY LF 7**

\*Introduce the gravity of your zone before doing the first calibration.

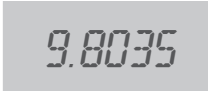
\*Introduce the gravity of destination after doing the calibration.

\*The value of the gravity will be denied if it is bigger than 9.83217 ( gravity of the pole) or inferior to 9.78031 ( gravity of the equator).















Value of factory: 9.8035

DISPLAY	DESCRIPTION AND SEQUENCE OF USE
 	<ul style="list-style-type: none"> <li>Press the key  to continue or the key  to exit from the menu and the scale will start again automatically.</li> </ul>
	<ul style="list-style-type: none"> <li>The screen is going to show the number of pre-calibration during one second.</li> </ul>
 	<ul style="list-style-type: none"> <li>Press the key  to continue.</li> </ul>
 	<ul style="list-style-type: none"> <li>Use the keys ,  and , <b>0 ~ 9</b> and then the key  to introduce the value of gravity ( press ESC to exit from the configuration and go back to the menu LF7)</li> </ul>

**INITIAL ZERO LF 8**

**SEtZ Y** resets of the point of zero every time that the scale is begun again.

**SEtZ n** resets of the point zero OFF

DISPLAY	DESCRIPTION AND SEQUENCE OF USE
 	<ul style="list-style-type: none"> <li>Press the key  to start or the key  to exit from the menu and the scale will start again automatically.</li> </ul>
 	<ul style="list-style-type: none"> <li>Use the key ,  then the key  to choose the mode of zero initial ( press the key  to exit from the configuration and go back to the menu LF8)</li> </ul>
	<ul style="list-style-type: none"> <li>Use the keys ,  and then the key  to continue with other adjustments or press the key  to exit from the menu and the scale will start again automatically.</li> </ul>

## 11. ERROR MESSAGES

MESSAGE	DESCRIPTION
	Zero point too high
	Zero point too high
	Zero point too high
	Zero point too low
	Zero point too low
	Weight is not stable
	Internal code is not stable
	Overloading
	Overloading
	Overloading
	Linearity correcting not well or linearity correcting cancel
	Weight is too low
	Internal code is too low
	E2ROM abnormal
	Total price is more than 999999
	Battery volume is too low

## 12. GUARANTEE

This scale has a warranty against all manufacture and material defects, for a period of a year starting with the delivery date.

During this period, GIROPES, will be in charge of the repairing of the scale.

This warranty does not include the damages done by overload or wrong use.

The warranty does not cover the delivery expenses necessary for the repair of the scale.

# 1. SPEZIFIKATIONEN

## BR16

Präzision	Klasse III
Empfindlichkeitsbereich der Wägezelle	1.5 ~ 3.0 mV/V
Keine Linearität	≤ 0.01 % F.S
Netzspannung Wägezelle	DC 5V
Stufe	1/2/5 (wählbar)
Stichprobenfrequenz	20x pro Sekunde (fällt nicht unter das Messwesen)
Interne Auflösung	300.000~600.000

# 2. STROMZUFUHR

## BR16

Eingang	100/240 VAC
Ausgang	12 V/1 A
Akku	6 V/4 Ah

# 3. VOR DER INBETRIEBNAHME

- 1) Stellen Sie die Waage auf eine feste und ebene Oberfläche, außerhalb von Erschütterungsbereichen.
- 2) Verwenden Sie eine separate Stromquelle, vermeiden Sie elektrische Störungen.
- 3) Wenn Sie die Anzeige einschalten darf sich kein Gegenstand auf der Wägeplatte befinden.
- 4) Warten Sie nach dem Einschalten 2-3 Minuten, damit sich die Waage vorwärmen kann.
- 5) Vermeiden Sie plötzliche Temperaturschwankungen und Zugluft.
- 6) Überladen Sie die Waage nicht und überschreiten Sie nie die Maximalkapazität.

# 4. VERBRAUCH

- Normalverbrauch im Standby: ca. 12 mA - 333 h
- Verbrauch mit Hintergrundbeleuchtung: ca. 36 mA - 111, 11h
- Verbrauch mit Hintergrundbeleuchtung und Ausgang RS-232: ca. 48 mA-83 h
- Lebensdauer der Batterie: ohne Hintergrundbeleuchtung, ca. 320 Stunden

# 5. ANSCHLUSS DER WAAGE AN DIE ANZEIGE

- 1) Der Stecker der Wägezelle hat 7 Stifte.
- 2) Ziehen Sie nicht den Stecker der Wägezelle, wenn die Anzeige in Betrieb ist. Dies kann zu Beschädigungen führen.

### SCHEMA WÄGEZELLE MIT 7 STIFTEN

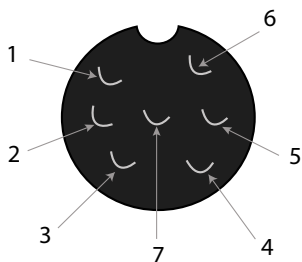
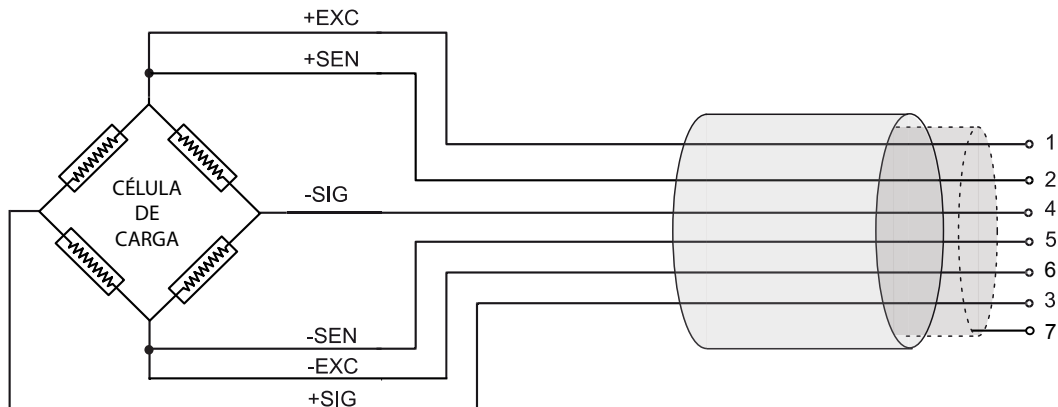

STIFT 1	EXC +
STIFT 2	SEN +
STIFT 3	SIG +
STIFT 4	SIG -
STIFT 5	SEN -
STIFT 6	EXC -
STIFT 7	GND

### ANSCHLUSS RS232

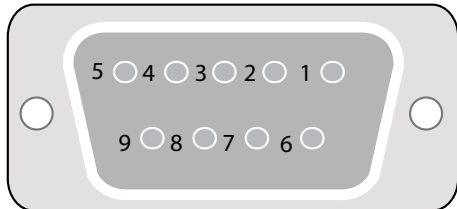

2	Tx
3	Rx
5	GND

### PROTOKOLL

UART signal of EIA-RS232 C

UART SIGNAL EIA-RS232 C	
Serienausgang	1200 / 2400 / 4800 / 9600 / 19200 / 34800 bps
Daten-Bits	8 Bit
Paritätsbits	Keine
STOPP-Bits	1 Bit

#### DATEN KOPFZEILE

Kopfzeile 1 (2 BYTE)	Kopfzeile 2 (2 BYTE)
OL – Überladen	
ST – Stabil	NT – Nettogewicht:
US – INSTABIL	GS – Bruttogewicht

## 6. BESCHREIBUNG DISPLAY UND TASTATUR

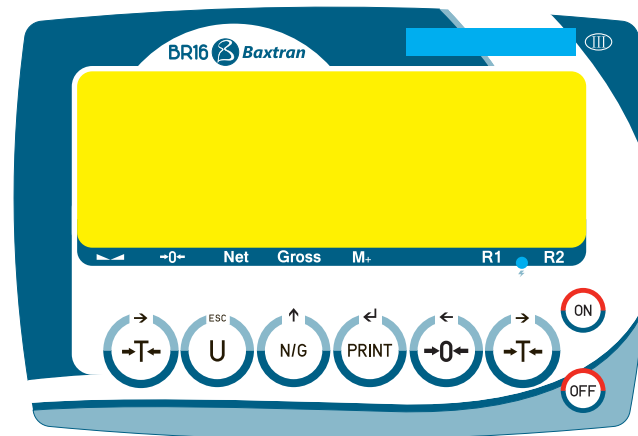

Drücken Sie diese Taste, um die Waage einzuschalten.



Halten Sie diese Taste für 2 Sekunden gedrückt, um die Anzeige auszuschalten.



**1. Funktion** Zum Wechseln der Wiegeeinheit.

**2. Funktion** Zum Verlassen des Menüs.



**1. Funktion** Um die Displayanzeige auf Null „0“ zu setzen, muss der angezeigte Wert weniger als  $\pm 2\%$  der Maximalkapazität betragen.

**2. Funktion** Um den Cursor im Programmiermodus eine Stelle nach links oder nach unten zu verschieben.



**1. Funktion** Um das Gewicht eines Behälters abzuziehen.

**2. Funktion** Um den Cursor im Programmiermodus eine Stelle nach rechts oder nach oben zu verschieben.



**1. Funktion** Um das Netto- oder Bruttogewicht eines Produkts anzuzeigen nachdem das Leergewicht ermittelt wurde. Wenn das Bruttogewicht eines Produkts angezeigt wird sind die anderen Tasten deaktiviert.

**2. Funktion** Um die Werte im Programmiermodus zu erhöhen.



**1. Funktion** Manuelle Datenübertragung auf einen PC oder Drucker über den Port RS-232 und gemäß ausgewähltem Modus.

**2. Funktion** Bestätigungstaste im Programmiermodus.

## 7. STÜCKZÄHLMODUS

1. Drücken Sie die Taste bis im Display Pcs erscheint.
2. Drücken Sie nacheinander , um die Stückzahl der Probe auszuwählen. Im Display erscheint nacheinander C 10 / C20 / C 50 / C 100 / C 200.
3. Stellen Sie Probe auf die Wägeplatte, warten Sie auf die Stabilitätsanzeige und drücken Sie die Taste .
4. Stellen Sie das Produkt auf die Wägeplatte. Im Display erscheint die Stückzahl.



Die Speicherung und Datenweiterleitung hängt vom unter Abschnitt UF-6 gewählten Modus ab.

- Um zum normalen Wiegemodus zurückzukehren, drücken Sie die Taste .
- Wenn Sie zum Stückzählmodus zurückkehren möchten verwenden Sie die gleiche Referenzprobe und drücken erneut die Taste .
- Möchten Sie die Referenzprobe wechseln, wiederholen Sie die oben beschriebenen Schritte.

## 8. KONFIGURATION DER PARAMETER

8.1	INTERNES ZÄHLEN (A/D)	UF-1
8.2	KONFIGURATION DER GEWICHTSGRENZEN (HÖCHST- UND MINDESGEWICHT)	UF-2
8.3	AUTOMATISCHES ABSCHALTEN	UF-3
8.4	KONFIGURATION DER DISPLAYBELEUCHTUNG	UF-4
8.5	HOLD-FUNKTION	UF-5
8.6	DATENAUSGANG RS-232	UF-6
8.7	KONFIGURATION DER GESCHWINDIGKEIT RS-232	UF-7
8.8	NULL-TEILWERT	UF-8
8.9	KONFIGURATION DER GRAVITATION	UF-9



Um zur Konfiguration der Parameter zu gelangen, drücken Sie gleichzeitig die Tasten  und .

Drücken Sie die Tasten  und , um durch das Menü zu navigieren (UF-1 ~ UF-9).









Drücken Sie die Taste , um auf den Parameter zuzugreifen und bestätigen Sie.

Drücken Sie die Taste , um das Menü zu verlassen und zum Wägemodus zurückzukehren.

### 8.1 INTERNES ZÄHLEN (A/D) | UF-1

1. Drücken Sie die Taste , um die interne Zählfunktion der Waage anzuzeigen.
2. Drücken Sie die Taste , um zum nächsten Parameter zu gelangen. Im Display erscheint die Batteriespannung.
3. Drücken Sie die Taste , um zum Menü *UF* zurück zu gelangen.

### 8.2 KONFIGURATION DER GEWICHTSGRENZEN (HÖCHST- UND MINDESGEWICHT) | UF-2

1. Drücken Sie die Taste , um auf den Parameter zuzugreifen.
2. Im Display erscheint die Meldung „000000L“ (Mindestgewicht).
3. Benutzen Sie die Tasten  und , um den Cursor zu bewegen und die Taste , um die gewünschte Zahl zu wählen.
4. Drücken Sie die Taste , um zu bestätigen.
5. Im Display erscheint die Meldung „00000H“ (Höchstgewicht).
6. Benutzen Sie die Tasten  und , um den Cursor zu bewegen und die Taste , um die gewünschte Zahl zu wählen.
7. Drücken Sie die Taste , um zu bestätigen.
8. Im Display erscheint der Wert

A	B	C
0	0	0

(Konfiguration des Alarms)



DISPLAY	WERT	STABILITÄT
A	0	Zum Ertönen wird keine Stabilität benötigt
	1	Zum Ertönen wird Stabilität benötigt
B	0	Immer 0
C	0	Alarm ausgeschaltet
	1	Alarm ertönt, wenn sich der Wert innerhalb des Bereiches <b>Ok befindet</b> (zwischen den Grenzwerten <b>Lo</b> und <b>Hi</b> )
	2	Alarm ertönt, wenn der Wert niedriger als der Mindestwert <b>Lo</b> oder höher als der Höchstwert <b>Hi</b> ist



9. Verwenden Sie die Tasten und , um den Cursor zu bewegen und die Taste , um die gewünschte Zahl auszuwählen.

10. Drücken Sie die Taste , um zu bestätigen.

Im Display erscheinen die Anzeigen **Lo, Ok, Hi** nach dem Gewicht.

### 8.3 AUTOMATISCHES ABSCHALTEN | UF-3

MODI:

<i>RoFF 00</i>	Automatisches Abschalten deaktiviert.
<i>RoFF 01</i>	Automatisches Abschalten aktiviert. Die Waage schaltet sich automatisch ab, wenn innerhalb von 1 Minute keine Aktion durchgeführt wird. Wählen Sie die Abschaltzeit zwischen 1 und 99 Minuten.



1. Drücken Sie die Taste , um auf den Parameter zuzugreifen.
2. Verwenden Sie die Tasten und , um den Cursor zu bewegen und die Taste , um die gewünschte Zeit auszuwählen.
3. Drücken Sie die Taste , um zu bestätigen.

### 8.4 KONFIGURATION DER DISPLAYBELEUCHTUNG | UF-4

MODI:

<i>A</i>	Automatisch.
<i>ON</i>	Beleuchtung immer an.
<i>OFF</i>	Beleuchtung deaktiviert.



1. Drücken Sie die Taste , um auf den Parameter zuzugreifen.

2. Drücken Sie die Taste , um den gewünschten Modus auszuwählen.
3. Drücken Sie die Taste , um zu bestätigen.

## 8.5 HOLD-FUNKTION | UF-5

Im Modus **HOLD** bleibt nach Entfernen des Objekts von der Wägeplatte das Gewicht im Display stehen, bis  gedrückt wird. Sehr nützliche Funktion, zum Wiegen von Tieren. **Bitte beachten: Wenn Sie den Hold-Modus aktiviert haben,**









**KÖNNEN SIE WEDER DIE GRENZWERT- NOCH DIE SPEICHERFUNKTION VERWENDEN.**

1. Drücken Sie die Taste , um auf den Parameter zuzugreifen.
2. Drücken Sie die Taste , um den gewünschten Modus auszuwählen.
3. Drücken Sie die Taste , um zu bestätigen.

MODI:



- **HOLD 0** : Deaktiviert.
- **HOLD 1** : Tier in Bewegung.
- **HOLD 2** : Scheitelwert.
- **HOLD 3** : Hold stabil.
- **HOLD 4** : Hold stabil mit Auto-Löschen auf Null.

### HOLD 1.

- Wurde dieser Parameter ausgewählt, zeigt das Display **Pct**.
- Verwenden Sie die Tasten  und , um den Cursor zu bewegen und die Taste , um den gewünschten Wert des HOLD-Bereiches von 001 bis 100 auszuwählen.
- Drücken Sie die Taste , um zu bestätigen.
- Im Display erscheint **time 8**. Verwenden Sie die Tasten  und , um den Cursor zu bewegen und die Taste , um die gewünschte Anzahl an Wiederholungen im Hold-Bereich auszuwählen.
- Drücken Sie die Taste , um zu bestätigen.

*Beispiel: Pct niedrig und time hoch bedeutet mehr Präzision und mehr Zeit zur Stabilisierung.*

## 8.6 DATENAUSGANG RS-232 | UF-6

1. Drücken Sie die Taste , um auf den Parameter zuzugreifen.
2. Drücken Sie die Taste , um die gewünschte Übertragungsgeschwindigkeit auszuwählen.
3. Drücken Sie die Taste , um zu bestätigen.

**DATENFORMAT**

**Kein Format**

**232 0** Ausgang RS-232 deaktiviert

**Format 1 PC**

AUTOMATISCHES FORMAT VON GEWICHT ODER STÜCK

ST,GS,+0003. 58 kg <CR><LF>

ST,GS,+0000250pcs <CR><LF>

RASTERÜBERMITTLUNG

**232 1** Rasterübermittlung, ohne Speicherung, wenn bleibende Stabilität mit **Format 1**.

**232 2** Rasterübermittlung wird fortgesetzt mit **Format 1**.

**232 3** Rasterübermittlung, ohne Speicherung, durch Drücken der Taste  mit **Format 1**.

**Format 2 PC**

AUTOMATISCHES FORMAT VON GEWICHT ODER STÜCK

+0000.64kg <CR><LF>

+0000100pcs <CR><LF>

RASTERÜBERMITTLUNG

**232 4** Rasterübermittlung, ohne Speicherung, wenn bleibende Stabilität mit **Format 2**.

**232 5** Rasterübermittlung wird fortgesetzt mit **Format 2**.

**232 6** Rasterübermittlung, ohne Speicherung, durch Drücken der Taste  mit **Format 2**.

**Format 3 Drucker**

AUTOMATISCHES FORMAT VON GEWICHT ODER STÜCK

S/N	WT/kg	S/N	WT/pcs
0001	0.64	0001	20
0002	0.70	0002	21
0003	0.64	0003	45
-----		-----	
0003	1.98	0003	86

**232 7** Rasterübermittlung und manuelles Speichern über Null und durch Drücken der Taste  mit **Format 3**.

0002 0.70

Wenn das Display 0 zeigt, drücken Sie zweimal nacheinander die Taste . Die Summenzeile wird gedruckt.

-----  
0003 1.98

Der Wägespeicher wird gelöscht.

Bitte beachten: Speicherung und Summierung nicht durch rechtliches Messwesen erhältlich.

RASTERÜBERMITTLUNG

**232 8** Rasterübermittlung und automatisches Speichern bei Stabilität, über 0 mit **Format 3**.

0002 21

Wenn das Display 0 zeigt, drücken Sie zweimal nacheinander die Taste . Die Summenzeile wird gedruckt.

-----  
0003 86

Der Wägespeicher wird gelöscht.

Bitte beachten: Speicherung und Summierung nicht durch rechtliches Messwesen erhältlich.

**Format 4 Drucker**

AUTOMATISCHES  
FORMAT VON GEWICHT  
ODER STÜCK

TICKET NO.0003  
G 0.64kg  
T 0.00kg  
N 0.64kg

TICKET NO.0002  
G 20pcs  
T 0pcs  
N 20pcs

TOTAL NUMBER  
OF TICKETS 0003  
TOTAL  
NET 1.92



TOTAL NUMBER  
OF TICKETS 0002  
TOTAL  
NET 40

**HINWEIS:** Summierung nicht durch rechtliches Messwesen erhältlich.

**RASTERÜBERMITTLUNG 232 9**

Rasterübermittlung und manuelles Speichern über Null und durch Drücken der Taste  mit **Format 4**.

Wenn das Display 0 zeigt, drücken Sie zweimal nacheinander die Taste . Das Kartenergebnis wird gedruckt.

Bei neueren Versionen ist es möglich, dass der Benutzer  drücken muss und beim Anzeigen der Anzahl und des Gewichts der Akkumulationen  drücken muss, um die Werte auszudrucken und gleichzeitig den Speicher zu löschen.

Der Wägespeicher wird gelöscht.

**HINWEIS:** Summierung nicht durch rechtliches Messwesen erhältlich.



TICKET NO.0003  
G 0.64kg  
T 0.00kg  
N 0.64kg

TOTAL NUMBER  
OF TICKETS 0003  
TOTAL  
NET 1.92

**RASTERÜBERMITTLUNG 232 10**

Rasterübermittlung und automatisches Speichern bei Stabilität, über Null und durch Drücken der Taste  mit **Format 4**.

Wenn das Display 0 zeigt, drücken Sie zweimal nacheinander die Taste . Das Kartenergebnis wird gedruckt.

Bei neueren Versionen ist es möglich, dass der Benutzer  drücken muss und beim Anzeigen der Anzahl und des Gewichts der Akkumulationen  drücken muss, um die Werte auszudrucken und gleichzeitig den Speicher zu löschen.

Der Wägespeicher wird gelöscht.

**HINWEIS:** Summierung nicht durch rechtliches Messwesen erhältlich.

TICKET NO.0002  
G 20pcs  
T 0pcs  
N 20pcs

TOTAL NUMBER  
OF TICKETS 0003  
TOTAL  
NET 1.92

**BITTE BEACHTEN:** IMMER wenn eine Speicherung erfolgt, zeigt das Display für 3 Sekunden die kummulierte Summe.

### FORMAT 1 (232 1 ~ 3):

18 BYTES ASCII FÜR DIE EINHEITEN kg, g, t, lb

1	2	,	1	2	,	1	2	3	4	5	6	7	8	1	2	CR	LF
Kopfzeile 1		Kopfzeile 2		Daten										Einheit			

21 BYTES ASCII FÜR DIE EINHEITEN tl, T, lboz

1	2	,	1	2	,	1	2	3	4	5	6	7	8	9	1	2	3	4	CR	LF
Kopfzeile 1		Kopfzeile 2		Daten										Einheit						

19 BYTES ASCII FÜR DIE EINHEIT pcs

1	2	,	1	2	,	1	2	3	4	5	6	7	8	1	2	3	CR	LF
Kopfzeile 1		Kopfzeile 2		Daten										Einheit				

### FORMAT 2 (232 4 ~ 6):

12 BYTES ASCII FÜR DIE EINHEITEN kg, g, t, lb

1	2	3	4	5	6	7	8	1	2	CR	LF
Daten								Einheit			



15 BYTES ASCII FÜR DIE EINHEITEN tl, T, lboz

1	2	3	4	5	6	7	8	9	1	2	3	4	CR	LF
Daten								Einheit						

13 BYTES ASCII FÜR DIE EINHEIT pcs

1	2	3	4	5	6	7	8	1	2	3	CR	LF
Daten								Einheit				

## 8.7 KONFIGURATION DER GESCHWINDIGKEIT DES STROMRICHTERS | UF-7 (\*)

1. Drücken Sie die Taste , um auf den Parameter zuzugreifen.
2. Drücken Sie die Taste , um den gewünschten Modus auszuwählen.

Modus 1	Normal
Modus 2	Schnell
Modus 3	Langsam

3. Drücken Sie die Taste , um zu bestätigen.

## 8.8 NULL-TEILWERT | UF-8 (\*)



Das Display zeigt 0 bis die nächste ausgewählte Unterteilung erreicht wird. Es werden Werte ab dieser Unterteilung angezeigt.

Beispiel:





Waage mit e=2 g

Ziffersschritt hat 5 Unterteilungen

Es wird 0 angezeigt bis  $2 \times 5 = 10$  g erreicht wird. Der erste angezeigte Wert beträgt 12 g.

1. Drücken Sie die Taste  um auf den Parameter zuzugreifen.
2. Drücken Sie die Taste , um auszuwählen.
3. Drücken Sie die Taste , um zu bestätigen.

## 8.9 KONFIGURATION DER GRAVITATION | *UF-9* (\*)

1. Drücken Sie die Taste , um auf den Parameter zuzugreifen.
2. Um den Wert zu ändern, drücken Sie die Taste , dann verwenden Sie die Tasten  und , um den Cursor zu bewegen und die Taste  um die gewünschte Zahl auszuwählen.







## 9. KALIBRIERUNG (NUR FÜR AUTORISIERTES PERSONAL) (\*)



<b>9.1</b>	<b>KALIBRIERUNG VON NULL + GEWICHT (SPAN)</b>	<i>ECF-1</i>
<b>9.2</b>	<b>KALIBRIERUNG VON NULL</b>	<i>ECF-2</i>
<b>9.3</b>	<b>KALIBRIERUNG DES GEWICHTS (SPAN)</b>	<i>ECF-3</i>

0. Schieben Sie den internen Schalter auf CAL ON.
1. Drücken Sie im normalen Wägemodus die Tasten  und . Im Display erscheint die Meldung **ECF – 1**.
2. Drücken Sie die Tasten  und , um die gewünschte Funktion auszuwählen: **ECF-1, ECF-2 oder ECF-3**







### 9.1 KALIBRIERUNG VON NULL + GEWICHT | *ECF-1*

- Drücken Sie die Taste . Im Display erscheint CALZ.
- Drücken Sie die Taste  , um die Displayanzeige auf Null zu setzen.
- Drücken Sie die Tasten  und  , um den Cursor zu bewegen.
- Drücken Sie die Taste  und geben Sie den Wert des Kalibrierungsgewichts ein.
- Stellen Sie das Kalibrierungsgewicht auf die Wägeplatte und drücken Sie die Taste  , um die Kalibrierung zu starten sobald die Anzeige stabil ist.

### 9.2 KALIBRIERUNG VON NULL | *ECF-2*

- Drücken Sie die Taste . Im Display erscheint CALZ.
- Drücken Sie die Taste  , um die Displayanzeige auf Null zu setzen.
- Drücken Sie die Taste  , um die Kalibrierung durchzuführen.

### 9.3 KALIBRIERUNG DES GEWICHTS | *ECF-3*

- Drücken Sie die Taste . Im Display erscheint der Wert des Kalibrierungsgewichts.
- Drücken Sie die Tasten  und  , um den Cursor zu bewegen.
- Drücken Sie die Taste  , um den Wert des Kalibrierungsgewichts zu ändern.
- Drücken Sie die Taste  , um zu bestätigen.
- Stellen Sie das Kalibrierungsgewicht auf die Wägeplatte und drücken Sie die Taste  , um die Kalibrierung sobald zu starten.







## 10. TECHNISCHE PARAMETER















ÄNDERN SIE DIE TECHNISCHE PARAMETER NICHT, WENN DIES NICHT NOTWENDIG IST. EINE SCHLECHTE KONFIGURATION DIESES BEREICHS KANN ZUR FEHLFUNKTION DER WAAGE FÜHREN.

Handelt es sich um eine geprüfte Anzeige, öffnen Sie diese und tauschen Sie den Kalibrierschalter aus, wenn dieser auf CAL ON gestellt ist. Denken Sie daran, dass bei Beschädigung der Plombe die Verifizierung verloren geht.

### KALIBRIERUNG BEGINNEN UND BEENDEN

DISPLAY	BESCHREIBUNG und ABFOLGE
	<ul style="list-style-type: none"> <li>• DER INTERNE KALIBRIERSCHALTER MUSS AUF CAL ON GESTELLT SEIN.</li> <li>• DRÜCKEN Sie bei ausgeschalteter Anzeige die Taste  für längere Zeit, wodurch das Gerät eingeschaltet wird. Wenn im Display <i>100 1</i> erscheint, lassen Sie die Taste  los.</li> </ul> <p>Drücken Sie die Taste , um Zugriff auf die Tasten  zu erhalten oder , um den Parameter zu ändern.</p> <p>Drücken Sie die Taste  <b>U</b>, um das Menü zu verlassen. Die Anzeige startet automatisch neu.</p>

### KALIBRIERUNG DES GEWICHTS *LF 1*

DISPLAY	BESCHREIBUNG und ABFOLGE
	<p>Die Kalibrierung kann mit jedem Gewicht erfolgen, wobei die Last nicht kleiner als 1/3 der Maximalkapazität sein und die Waage niemals überladen werden darf.</p>
 	<ul style="list-style-type: none"> <li>• DRÜCKEN Sie die Taste , um die Null-Kalibrierung zu starten (drücken Sie  <b>U</b>, um die Kalibrierung zu beenden und zum Menü LF1 zurück zu kehren).</li> </ul>
 	<ul style="list-style-type: none"> <li>• Verwenden Sie ,  und , <b>0 ~ 9</b> und danach , um das Gewicht einzugeben mit dem die Kalibrierung durchgeführt werden soll. (Drücken Sie  <b>U</b>, um die Kalibrierung zu beenden und zum Menü LF1 zurück zu kehren).</li> </ul>

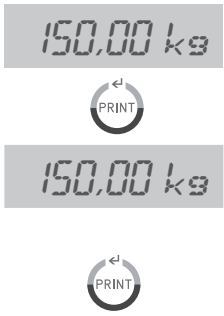



• Stellen Sie das erforderliche Gewicht auf die Waage, das im Display aufblinkt.

• Wenn sich die Anzeige stabilisiert, drücken Sie , um zu kalibrieren. (drücken Sie ESC, um die Kalibrierung zu beenden und zum Menü LF1 zurück zu kehren).

DIE KALIBRIERUNG WIRD BEENDET UND DIE WAAGE KEHRT AUTOMATISCH ZUM WÄGEMODUS ZURÜCK.

## KONFIGURATION *LF 2*

DISPLAY	BESCHREIBUNG und ABFOLGE																														
<b>ERSTER SCHRITT</b>																															
	<ul style="list-style-type: none"> <li>• ANZEIGE DER INTERNEN ZÄHLUNGEN</li> <li>• MÖGLICHE WERTE DER PARAMETER</li> </ul>																														
<b>ZWEITER SCHRITT</b>																															
																															
A B C D E F	<table border="0"> <tr> <td>A: Metrisches System</td> <td>0:NO</td> <td>1: kg</td> <td>2:T</td> <td>3: g</td> </tr> <tr> <td>B:Amerikanisches System</td> <td>0:NO</td> <td>1: lb</td> <td>2:lb oz</td> <td></td> </tr> <tr> <td>C: andere Einheiten</td> <td>0:NO</td> <td>1: TW kg</td> <td>2: HK kg</td> <td>3:VISS</td> </tr> <tr> <td>D: PCS</td> <td>0:OFF</td> <td>1: ON</td> <td></td> <td></td> </tr> <tr> <td>E: zweifacher Bereich</td> <td>0:OFF</td> <td>1: mehrere Intervalle</td> <td>2: mehrere Bereiche</td> <td></td> </tr> <tr> <td>F: Kalibrierungseinheiten</td> <td></td> <td>1: metrische Einheiten verwenden</td> <td>2: amerikanische Einheiten verwenden</td> <td></td> </tr> </table>	A: Metrisches System	0:NO	1: kg	2:T	3: g	B:Amerikanisches System	0:NO	1: lb	2:lb oz		C: andere Einheiten	0:NO	1: TW kg	2: HK kg	3:VISS	D: PCS	0:OFF	1: ON			E: zweifacher Bereich	0:OFF	1: mehrere Intervalle	2: mehrere Bereiche		F: Kalibrierungseinheiten		1: metrische Einheiten verwenden	2: amerikanische Einheiten verwenden	
A: Metrisches System	0:NO	1: kg	2:T	3: g																											
B:Amerikanisches System	0:NO	1: lb	2:lb oz																												
C: andere Einheiten	0:NO	1: TW kg	2: HK kg	3:VISS																											
D: PCS	0:OFF	1: ON																													
E: zweifacher Bereich	0:OFF	1: mehrere Intervalle	2: mehrere Bereiche																												
F: Kalibrierungseinheiten		1: metrische Einheiten verwenden	2: amerikanische Einheiten verwenden																												





lb oz können nicht als Kalibriereinheiten ausgewählt werden.

Der nächste Schritt kann nicht ausgeführt werden, wenn während der Programmierung ein Fehler auftritt.



### DRITTER SCHRITT

Nach dem Zugreifen auf die Parameter LF2 erscheint in der Anzeige die letzte gespeicherte Konfiguration. Alle Schritte müssen abgeschlossen werden. Andernfalls kehrt die Anzeige zur vorigen Konfiguration zurück.





Führen Sie nach Konfiguration von LF2 die Kalibrierung des Gewichts aus.

• Drücken Sie die Taste , um zu beginnen. Es erscheint der INTERNE WERT. Drücken Sie , um das Menü zu verlassen. Die Waage startet automatisch neu.

LF2  

• Drücken Sie , um mit der Konfiguration fortzufahren. (Drücken Sie , um die Konfiguration zu beenden und zum Menü LF2 zurück zu kehren).





262 144  

• Verwenden Sie ,  und , und dann , um die EINHEITEN UND DEN WÄGEMODUS gemäß der vorstehenden Tabelle auszuwählen. (Drücken Sie , um die Kalibrierung zu beenden und zum Menü LF2 zurück zu kehren).



10000 1  

• Verwenden Sie ,  und , und dann , um die MAXIMALKAPAZITÄT auszuwählen. Dabei müssen Sie die Anzahl der Dezimalzeichen beachten, die im nächsten Schritt ausgewählt wird. (Drücken Sie , um die Kalibrierung zu beenden und zum Menü LF2 zurück zu kehren).

000000k<sub>g</sub>  

• Verwenden Sie ,  und dann , um den Dezimalpunkt zu bewegen. (drücken Sie , um die Konfiguration zu beenden und zum Menü LF2 zurück zu kehren).

d 0.0k<sub>g</sub>  

• Verwenden Sie , und dann , um die Stufe zu ändern (drücken Sie , um die Konfiguration zu beenden und zum Menü LF2 zurück zu kehren).

d v 0 1  

• Verwenden Sie ,  und , um mit anderen Konfigurationen fortzufahren oder drücken Sie , um das Menü zu verlassen. Die Waage startet automatisch neu).

LF2  

## GESCHWINDIGKEIT DES STROMRICHTERS AD LF4

**SPEED 1** Standardgeschwindigkeit 15Hz.

**SPEED 2** hohe Geschwindigkeit 30Hz.

**SPEED 3** niedrige Geschwindigkeit 7.5Hz

\*Diese Funktion ist gesperrt, wenn UF-5 sich im HOLD-Modus 1 befindet.

\*Die Werkseinstellung ist 1

**DISPLAY**

**BESCHREIBUNG und ABFOLGE**



• Drücken Sie , um zu beginnen oder , um das Menü zu verlassen. Die Waage startet automatisch neu.

• Verwenden Sie und dann , um die Geschwindigkeit des Stromrichters AD auszuwählen (drücken Sie , um die Konfiguration zu beenden und zum Menü LF4 zurück zu kehren).

• Verwenden Sie , und dann , um mit anderen Einstellungen fortzufahren oder drücken Sie , um das Menü zu verlassen. Die Waage startet automatisch neu.

**TEILWERT LF 5**

**DISPLAY**

**BESCHREIBUNG und ABFOLGE**



**ZP 0** OFF

**ZP 1** Eine Unterteilung befindet sich nicht auf Null

**ZP 2** Zwei Unterteilungen befinden sich nicht auf Null

**ZP 3** Drei Unterteilungen befinden sich nicht auf Null

**ZP 4** Vier Unterteilungen befindet sich nicht auf Null

**ZP 5** Fünf Unterteilungen befinden sich nicht auf Null

\*Diese Funktion ist gesperrt, wenn UF-5 sich im HOLD-Modus 1 befindet

\*Die Werkseinstellung ist ZP 0

**DISPLAY**

**BESCHREIBUNG und ABFOLGE**



• Drücken Sie , um zu beginnen oder , um das Menü zu verlassen. Die Waage startet automatisch neu.

• Verwenden Sie und dann , um die Unterteilungen auszuwählen, die sich nicht auf Null befinden. (Drücken Sie **ESC**, um die Konfiguration zu beenden und zum Menü LF4 zurück zu kehren).



• Verwenden Sie , und dann , um mit anderen Einstellungen fortzufahren oder drücken Sie , um das Menü zu verlassen. Die Waage startet automatisch neu.

**ZULASSUNGSGENEHMIGUNG LF 6**

**DISPLAY**

**BESCHREIBUNG und ABFOLGE**



**nonE** nicht genehmigte Version **OIML** genehmigte Version

**MODIFIZIEREN SIE DIESEN PARAMETER UNTER KEINEN UMSTÄNDEN.**

Die Änderung dieses Parameters bedeutet, dass verschiedene Funktionalitäten blockiert werden.







**GRAVITATION LF 7**

\*Geben Sie die Gravitation Ihres Gebietes ein bevor Sie die erste Kalibrierung durchführen.

\*Geben Sie die Gravitation des Bestimmungsortes ein nachdem Sie die erste Kalibrierung durchgeführt haben.

\*Der Gravitationswert wird abgelehnt, wenn er größer als 9.83217 (Polgravitation) oder kleiner als 9.78031 ist (Gravitation des Äquators).













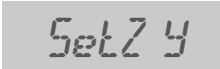

Werkseinstellung: 9.801

DISPLAY	BESCHREIBUNG und ABFOLGE
	• Drücken Sie  , um fortzufahren oder  , um das Menü zu verlassen. Die Waage startet automatisch neu.
	
	• Im Display erscheint für eine Sekunde die Zahl der Vorkalibrierung.
	• Drücken Sie  , um fortzufahren.
	
	• Verwenden Sie  ,  ,  , <b>0 ~ 9</b> und dann  , um den Gravitationswert einzugeben. (Drücken Sie ESC, um die Konfiguration zu beenden und zum Menü LF 7 zurück zu kehren).
	

**START-NULL LF 8**

**SEtZ Y** setzt den Nullpunkt immer zurück wenn die Waage neu startet

**SEtZ n** Zurücksetzen des Nullpunktes Off

DISPLAY	BESCHREIBUNG und ABFOLGE
	• Drücken Sie  , um zu beginnen oder  , um das Menü zu verlassen. Die Waage startet automatisch neu.
	
	• Verwenden Sie  ,  , dann  , um den Modus Start-Null auszuwählen. (Drücken Sie  , um die Konfiguration zu beenden und zum Menü LF8 zurück zu kehren).
	• Verwenden Sie  ,  , und dann  , um mit anderen Einstellungen fortzufahren oder drücken Sie  , um das Menü zu verlassen. Die Waage startet automatisch neu.
	

## 11. FEHLERMELDUNGEN

MELDUNGEN	BESCHREIBUNG
Err H	Nullpunkt zu hoch
Z Err	Nullpunkt zu hoch
Err 1	Nullpunkt zu hoch
Err L	Nullpunkt zu niedrig
Err 2	Nullpunkt zu niedrig
Err N	Das Gewicht ist nicht stabil
E4	Interner Code ist nicht stabil
OL	Überlastung
O Err	Überlastung
hhhhhh	Überlastung
E3	Linearitätskorrektur nicht gut oder Linearitätskorrektur abrechen
LLLLLL	Das Gewicht ist zu niedrig
E5	Interner Code ist zu niedrig
Err4	E2ROM abnormal
-----	Der Gesamtpreis beträgt mehr als 999999
B Err	Das Akkuvolumen ist zu niedrig

## **12. GARANTIE**

Sie erhalten ab Lieferdatum 1 Jahr Garantie auf alle Herstellungs- und Materialfehler.

In diesem Zeitraum übernimmt GIROPÈS die Reparaturkosten für die Anzeige.

Schäden durch unsachgemäße Verwendung oder Überlast sind von der Garantie ausgenommen.

Die Versandkosten (Fracht) für die Reparatur der Anzeige werden nicht von der Garantie abgedeckt.

# 1. ESPECIFICAÇÕES

## BR16

	Precisão	Classe III
Intervalo de sensibilidade da célula de carga		1,5 ~ 3,0 mV/V
	Sem linearidade	≤0,01%F.S
	Voltagem da célula	DC 5V
	Escalão	1/2/5 (selecionável)
Frequência de amostragem		20 vezes por segundo (fora da meteorologia)
	Resolução interna	300 000~600 000

# 2. ALIMENTAÇÃO ELÉTRICA

## BR16

	Entrada	100/240VAC
	Saída	12V/1A
	Bateria recarregável	6V/4Ah

# 3. ANTES DA UTILIZAÇÃO

- 1) Coloque a balança sobre uma superfície firme e nivelada, não a exponha a ambientes vibratórios.
- 2) Utilize uma fonte de alimentação independente, evitar perturbações elétricas.
- 3) Não coloque nenhum objeto na plataforma no momento de iniciar o indicador.
- 4) Por favor, deixe a balança aquecer durante 2 a 3 minutos antes da utilização.
- 5) Evite mudanças bruscas de temperatura e correntes de ar.
- 6) Não sobrecarregar a balança, nunca exceder a capacidade máxima.

# 4. CONSUMO

- Consumo normal em standby: aprox. 12mA - 333h
- Consumo com retroiluminação: aprox. 36mA - 111,11h
- Consumo com retroiluminação e saída RS-232: aprox. 48mA-83h
- Duração da bateria: sem retroiluminação, aprox. 320 horas

# 5. LIGAÇÃO DA CÉLULA DE CARGA AO INDICADOR

- 1) O conector da célula de carga é um conector de 7 pinos.
- 2) Quando o indicador estiver a funcionar, não retire o conector da célula de carga, isto pode danificar o equipamento

## ESQUEMA DA CÉLULA DE 7 PINOS

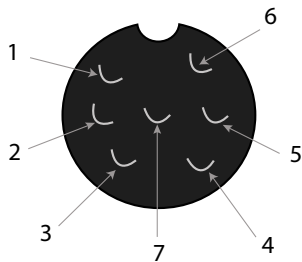
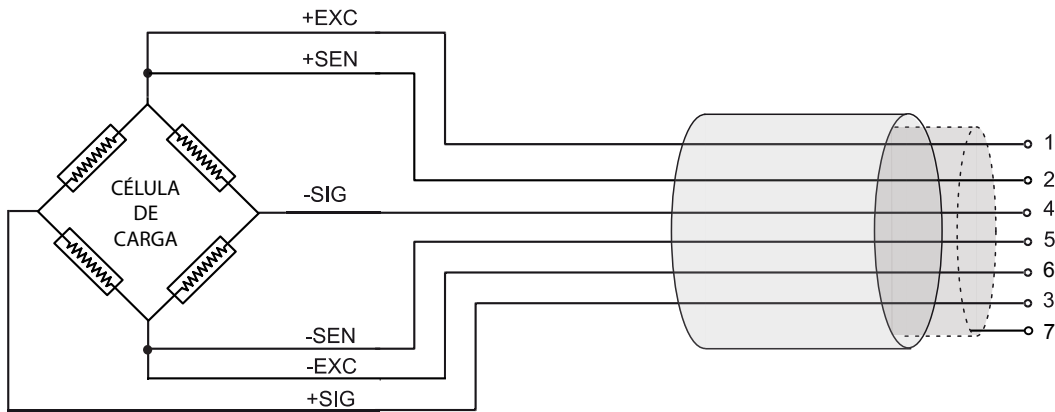

PIN 1	EXC +
PIN 2	SEN +
PIN 3	SIG +
PIN 4	SIG -
PIN 5	SEN -
PIN 6	EXC -
PIN 7	GND

## LIGAÇÃO RS232

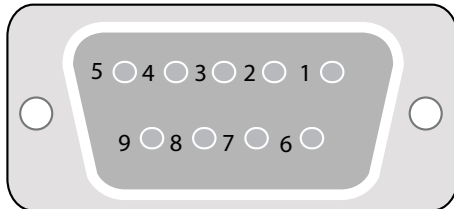

2	Tx
3	Rx
5	GND

## PROTOCOLO

Sinal UART do EIA-RS232 C

SINAL UART DO EIA-RS232 C	
Série de saída	1200 / 2400 / 4800 / 9600 / 19200 / 34800 bps
Bits de dados	8 bits
Bits de paridade	No
Bits de paragem	1 bit

### INFORMAÇÃO DOS CABEÇALHOS

Cabeçalho 1 (2 BYTES)	Cabeçalho 2 (2 BYTES)
OL – Sobrecarga	
ST - Estável	NT - Peso líquido
US - INSTÁVEL	GS - Peso bruto

## 6. DESCRIÇÃO DO VISOR E DO TECLADO

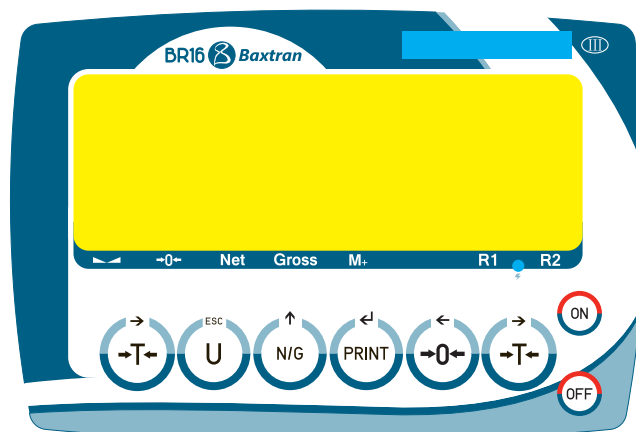

Prima esta tecla para ligar a balança.



Manter premida esta tecla durante 2 segundos para desligar o indicador.



**1º função** Para alterar a unidade de pesagem.

**2º função** Para sair de um menu.



**1º função** Para definir a leitura de visualização a zero "0", o valor de visualização tem que ser inferior a  $\pm 2\%$  da capacidade máxima.

**2º função** Para percorrer um espaço para a esquerda ou para baixo dentro do modo de programação.



**1º função** Para subtrair o peso de um recipiente.

**2º função** Para percorrer um espaço para a direita ou para cima dentro do modo de programação.



**1º função** Para visualizar o peso líquido ou bruto de um produto quando uma Tara tiver sido realizada. Quando o peso bruto do produto é visualizado, as outras teclas ficam desativadas.

**2º função** Para incrementar os valores dentro do modo de programação.



**1º função** Transmissão manual de dados através da porta RS-232 para um PC ou impressora, segundo o modo selecionado.

**2º função** Tecla de confirmação dentro do modo de programação.

## 7. MODO DE CONTAGEM DE PEÇAS

1. Pressione a tecla até o visor mostrar Pcs.
2. Pressione sucessivamente para selecionar a quantidade de peças da amostra. O visor mostrará sucessivamente C 10 / C 20 / C 50 / C 100 / C 200.
3. Colocar a amostra na plataforma, aguardar que o indicador de estabilidade acenda e pressione a tecla .
4. Colocar o produto na plataforma e o visor mostrará o número de peças.

A acumulação e o envio de dados dependerá do modo selecionado na secção UF-6.

- Para voltar ao modo de pesagem normal, pressione a tecla .
- Se desejar voltar ao modo de contagem de peças, utilizando a mesma amostra de referência, pressione novamente a tecla .
- Se desejar alterar a amostra de referência, repita os passos descritos acima.



## 8. CONFIGURAÇÃO DE PARÂMETROS

8.1	CONTAS INTERNAS (A/D)	UF-1
8.2	CONFIGURAÇÃO DOS LIMITES DE PESO (SUPERIOR E INFERIOR)	UF-2
8.3	DESLIGAR AUTOMÁTICO	UF-3
8.4	CONFIGURAÇÃO DA ILUMINAÇÃO DO VISOR	UF-4
8.5	FUNÇÃO HOLD	UF-5
8.6	SAÍDA DE DADOS RS-232	UF-6
8.7	CONFIGURAÇÃO DA VELOCIDADE RS-232	UF-7
8.8	MÉDIA DO ZERO	UF-8
8.9	CONFIGURAÇÃO DA GRAVIDADE	UF-9



Para aceder à configuração dos parâmetros, pressionar ao mesmo tempo as teclas  e .

Prima as teclas  e  para navegar através do menu (UF-1 ~ UF-9).









Prima a tecla  para aceder ao parâmetro e confirmar.

Prima a tecla  para sair do menu e voltar ao modo de pesagem.

### 8.1 CONTAS INTERNAS (A/D) | UF-1

1. Prima a tecla  para visualizar as contas internas da balança.
2. Para passar ao parâmetro seguinte, prima a tecla  e o visor mostrará a voltagem da bateria.
3. Prima a tecla  para voltar ao menu *UF*.

### 8.2 CONFIGURAÇÃO DOS LIMITES DE PESO (SUPERIOR E INFERIOR) | UF-2

1. Prima a tecla  para aceder ao parâmetro.
2. O visor mostrará a mensagem "000000L" (Limite inferior).
3. Utilizar as teclas  e  para mover o cursor e a tecla  para seleccionar o número desejado.
4. Prima a tecla  para confirmar.
5. O visor mostrará "000000H" (Limite superior).
6. Utilizar as teclas  e  para mover o cursor e a tecla  para seleccionar o número desejado.
7. Prima a tecla  para confirmar.
8. O visor mostrará o valor

A	B	C
0	0	0

(configuração do alarme)

VISOR	VALOR	ESTABILIDADE
A	0	não é necessário estabilidade para soar
	1	é necessário estabilidade para soar
B	0	sempre 0
C	0	alarme desligado
	1	o alarme soa se estiver dentro do intervalo <b>Ok</b> (entre os limites <b>Lo</b> e <b>Hi</b> )
	2	o alarme soa se estiver abaixo do limite inferior <b>Lo</b> ou acima do limite superior <b>Hi</b>

LO	OK	HI
----	----	----

LO	OK	HI
----	----	----

9. Utilizar as teclas  e  para mover o cursor e a tecla  para seleccionar o número desejado.





10. Prima a tecla  para confirmar.

As indicações do visor **Lo**, **Ok**, **Hi** aparecerão no visor de acordo com o peso.

## 8.3 DESLIGAR AUTOMÁTICO | UF-3

MODALIDADES:



<b>RoFF 00</b>	Desligar desativado.
<b>RoFF 01</b>	Desligar ativado, a balança desliga-se automaticamente após 1 minuto de não utilização. Selecionar o tempo de desligar automático entre 1 e 99 minutos.

1. Prima a tecla  para aceder ao parâmetro.
2. Utilizar as teclas  e  para mover o cursor e a tecla  para selecionar o tempo desejado.
3. Prima a tecla  para confirmar.

## 8.4 CONFIGURAÇÃO DA ILUMINAÇÃO DO VISOR | UF-4



MODALIDADES:

<b>A</b>	Automática.
<b>ON</b>	Iluminação sempre ligada/ativada.
<b>OFF</b>	Iluminação desativada.

1. Prima a tecla  para aceder ao parâmetro.
2. Prima a tecla  para selecionar o modo desejado.
3. Prima a tecla  para confirmar.

## 8.5 FUNÇÃO HOLD | UF-5













O modo **HOLD** permite que, uma vez retirado o objeto do prato da balança, o visor mantenha o peso fixo até que à pressão de  (função muito útil para a pesagem de animais). **Nota: se tiver ativado o modo hold, NÃO PODE UTILIZAR A FUNÇÃO DE LIMITES NEM A DE ACUMULAÇÃO.**

1. Prima a tecla  para aceder ao parâmetro.
2. Prima a tecla  para selecionar o modo desejado.
3. Prima a tecla  para confirmar.

MODALIDADES:



- **HOLD 0** : Desativado.
- **HOLD 1** : Animal em movimento.
- **HOLD 2** : Valor máximo.
- **HOLD 3** : Hold estável.
- **HOLD 4** : Hold estável com auto-cancelamento a zero.

**HOLD 1.**

- Uma vez acedido este parâmetro, o visor mostra **PCt**,
- Utiliza as teclas   e   para mover o cursor e a tecla  para seleccionar o valor desejado do intervalo de HOLD de 001 a 100.
- Prima a tecla  para confirmar.
- O visor mostrará **time 8**, utilize as teclas   e   para mover o cursor e a tecla  para seleccionar o número desejado de repetições durante o intervalo de hold.
- Prima a tecla  para confirmar.

*Exemplo: PCt pequeno e time grande implica mais precisão e tempo de estabilização mais longo.*

**8.6 SAÍDA DE DATOS RS-232 | UF-6**

1. Prima a tecla  para aceder ao parâmetro.
2. Prima a tecla  para seleccionar a velocidade de transmissão desejada.
3. Prima a tecla  para confirmar.

**FORMATO DOS DADOS**

**Sem formato**

**232 0** Saída RS-232 Desativada

**Formato 1 PC**

FORMATO AUTOMÁTICO DE

ST,GS,+0003. 58 kg <CR><LF>

PESO OU PEÇAS

ST,GS,+0000250pcs<CR><LF>

ENVIO DE DADOS

**232 1** Envio de dados, sem acumulação, quando alcança estabilidade com o **formato 1**.

**232 2** Envio contínuo de dados com o **formato 1**.

**232 3** Envio de dados, sem acumulação, manual, pressionando a tecla  com o **formato 1**.

**Formato 2 PC**

FORMATO AUTOMÁTICO DE

+0000.64kg<CR><LF>

PESO OU PEÇAS

+0000100pcs<CR><LF>

ENVIO DE DADOS

**232 4** Envio de dados, sem acumulação, quando alcança estabilidade com o **formato 2**.

**232 5** Envio contínuo de dados com o **formato 2**.

**232 6** Envio de dados, sem acumulação, manual, pressionando a tecla  com o **formato 2**.

**Formato 3 impressora**

FORMATO AUTOMÁTICO  
DE PESO OU PEÇAS

S/N	WT/kg
0001	0.64
0002	0.70
0003	0.64
-----	
0003	1.98

S/N	WT/pcs
0001	20
0002	21
0003	45
-----	
0003	86

**232 7** Envio de dados e acumulação manual, passando por zero e pressionando a tecla  com o **formato 3**.

0002 0.70

Se o visor estiver a 0, pressiona-se duas vezes seguidas a tecla  e imprime-se a linha do total.

-----  
0003 1.98

E a memória das pesagens é apagada.

Nota: Acumulação e totalização não disponíveis para metrologia legal.

ENVIO DE DADOS

**232 8** Envio de dados e acumulação automática para estabilidade, passando por 0 com o **formato 3**.

0002 21

Se o visor estiver a 0, pressiona-se duas vezes seguidas a tecla  e imprime-se a linha do total.

-----  
0003 86

E a memória das pesagens é apagada.

Nota: Acumulação e totalização não disponíveis para metrologia legal

**Formato 4 impressora**

FORMATO AUTOMÁTICO  
DE PESO OU PEÇAS

TICKET NO.0003	
G	0.64kg
T	0.00kg
N	0.64kg
TOTAL NUMBER OF TICKETS 0003	
TOTAL	
NET	1.92

TICKET NO.0002	
G	20pcs
T	0pcs
N	20pcs
TOTAL NUMBER OF TICKETS 0002	
TOTAL	
NET	40



**NOTA:** totalização não disponível em metrologia legal.

ENVIO DE DADOS

**232 9**

Envio de dados e acumulação manual, passando por zero e pressionando a tecla  com o **formato 4**

Se o visor estiver a 0, pressiona-se duas vezes seguidas a tecla  e imprime-se o resumo dos talões.

Nas novas Versões é possível que o utilizador tenha que pressionar  e ao mostrar o número e peso das acumulações, pressione  para imprimir os valores e apagar a memória ao mesmo tempo.

E a memória das pesagens é apagada

**NOTA:** totalização não disponível em metrologia legal.

TICKET NO.0003	
G	0.64kg
T	0.00kg
N	0.64kg



TOTAL NUMBER OF TICKETS 0003	
TOTAL	
NET	1.92

ENVIO DE DADOS

**232 10**

Envio de dados e acumulação automática para estabilidade, passando por zero e pressionando a tecla  com o **formato 4.**

Se o visor estiver a 0, pressiona-se duas vezes seguidas a tecla  e imprime-se o resumo dos talões.

Nas novas Versões é possível que o utilizador tenha que pressionar  e ao mostrar o número e peso das acumulações, pressione  para imprimir os valores e apagar a memória ao mesmo tempo.

E a memória das pesagens é apagada

**NOTA:** totalização não disponível em metrologia legal.

TICKET NO.0002	
G	20pcs
T	0pcs
N	20pcs

TOTAL NUMBER OF TICKETS 0003	
TOTAL	
NET	1.92

**NOTA:** Cada vez que é feita uma acumulação, o visor mostra o total acumulado durante 3 segundos.

### FORMATO 1 (232 1 ~ 3):

18 BYTES ASCII PARA AS UNIDADES kg, g, t, lb

1	2	,	1	2	,	1	2	3	4	5	6	7	8	1	2	CR	LF
Cabeçalho 1			Cabeçalho 2			Dados								Unidade			

21 BYTES ASCII PARA AS UNIDADES kg, g, t, lb

1	2	,	1	2	,	1	2	3	4	5	6	7	8	9	1	2	3	4	CR	LF
Cabeçalho 1			Cabeçalho 2			Dados									Unidade					

19 BYTES ASCII PARA A UNIDADE pcs

1	2	,	1	2	,	1	2	3	4	5	6	7	8	1	2	3	CR	LF
Cabeçalho 1			Cabeçalho 2			Dados								Unidade				

### FORMATO 2 (232 4 ~ 6):

12 BYTES ASCII PARA AS UNIDADES kg, g, t, lb

1	2	3	4	5	6	7	8	1	2	CR	LF
Dados								Unidade			



15 BYTES ASCII PARA AS UNIDADES ti, T, lboz

1	2	3	4	5	6	7	8	9	1	2	3	4	CR	LF
Dados									Unidade					

13 BYTES ASCII PARA A UNIDADE pcs

1	2	3	4	5	6	7	8	1	2	3	CR	LF
Dados								Unidade				

## 8.7 CONFIGURAÇÃO DA VELOCIDADE DO CONVERSOR | UF-7(\*)

1. Prima a tecla  para aceder ao parâmetro.
2. Prima a tecla  para seleccionar o modo desejado.

Modalidade 1 Normal

Modalidade 2 Rápida

Modalidade 3 Lenta

3. Prima a tecla  para confirmar.

## 8.8 ZERO CEGO/INVISÍVEL | UF-8(\*)



Apresenta 0 no visor até chegar à próxima divisão seleccionada. Começando a mostrar valores a partir desta divisão.

Exemplo:

balança/báscula com e=2g

invisível/cega em 5 divisões

Mostrará 0 até atingir 2x5=10g o primeiro valor que mostrará será 12g.

1. Prima a tecla  para aceder ao parâmetro.
2. Prima a tecla  para seleccionar.
3. Prima a tecla  para confirmar.

## 8.9 CONFIGURAÇÃO DA GRAVIDADE | *UF-9* (\*)





1. Prima a tecla  para aceder ao parâmetro.
2. Para alterar o valor, prima a tecla , depois utilize as teclas  e  para mover o cursor e a tecla para seleccionar o número desejado.

## 9. CALIBRAÇÃO (APENAS PARA PESSOAL AUTORIZADO) (\*)



9.1	CALIBRAÇÃO DO ZERO + PESO (SPAN)	<i>ECF-1</i>
9.2	CALIBRAÇÃO DO ZERO	<i>ECF-2</i>
9.3	CALIBRAÇÃO DO PESO (SPAN)	<i>ECF-3</i>

0. Mover o switch interno para CAL ON.

1. Dentro da modalidade normal de pesagem, prima as teclas  e , o visor mostrará a mensagem **ECF-1**.
2. Prima as teclas  e  para seleccionar a função desejada: **ECF-1, ECF-2 ou ECF-3**

### 9.1 CALIBRAÇÃO DO ZERO + PESO | *ECF-1*

Prima a tecla , o visor mostrará CALZ.

Prima a tecla , para colocar a leitura do visor a zero.

Prima as teclas  e  para mover o cursor.

Prima a tecla , para introduzir o valor da pesagem de calibração.

Coloque o peso de calibração na plataforma e prima a tecla  para efetuar a calibração assim que a leitura estiver estável.

### 9.2 CALIBRAÇÃO DO ZERO | *ECF-2*

Prima a tecla , o visor mostrará CALZ.

Prima a tecla , para colocar a leitura do visor a zero.

Prima a tecla , para efetuar a calibração.

### 9.3 CALIBRAÇÃO DO PESO | *ECF-3*

Prima a tecla , o visor mostrará o valor do peso de calibração

Prima as teclas  e  para mover o cursor.

Prima a tecla , para alterar o valor do peso de calibração.

Prima a tecla , para confirmar.

Coloque o peso de calibração na plataforma e prima a tecla  para efetuar a calibração assim que a





## 10. PARÂMETROS TÉCNICOS















NÃO ALTERE OS PARÂMETROS TÉCNICOS A MENOS QUE SEJA ESTRITAMENTE NECESSÁRIO. A CONFIGURAÇÃO INCORRETA DESTA SECÇÃO PODE CAUSAR O MAU FUNCIONAMENTO DA BALANÇA.

No caso de visores verificados, abra o visor e altere o interruptor de calibração para a posição CAL ON. Neste caso, lembre-se que o rompimento dos lacres implica a perda da verificação.

### ENTRAR E SAIR DA CALIBRAÇÃO

VISOR	DESCRIÇÃO e SEQUÊNCIA DE UTILIZAÇÃO
	<ul style="list-style-type: none"> <li>• COM O INTERRUPTOR INTERNO NA POSIÇÃO CAL ON.</li> <li>• Com o visor desligado, pressione e mantenha pressionada a tecla  e ligue o equipamento, quando o ecrã mostrar <b>100 !</b>, deixe de pressionar a tecla .</li> </ul> <p>Pressione a tecla  para aceder às teclas  ou  para mudar de parâmetro e a tecla  para sair do menu e o visor será automaticamente reiniciado.</p>

### CALIBRAÇÃO DO PESO LF 1

VISOR	DESCRIÇÃO e SEQUÊNCIA DE UTILIZAÇÃO
	<p>A calibração pode ser efetuada com qualquer peso, mas o peso não deve ser inferior a 1/3 da capacidade máxima e nunca deve ser excedido.</p>
	<ul style="list-style-type: none"> <li>• Pressione a tecla  para iniciar a calibração do zero (pressione  para sair da calibração e voltar ao menu LF1)</li> </ul>
	<ul style="list-style-type: none"> <li>• Utilize ,  e , <b>0 ~ 9</b> e depois  para introduzir o peso com o qual será feita a calibração. (Pressione  para sair da calibração e voltar ao menu LF1)</li> </ul>
	<ul style="list-style-type: none"> <li>• Coloque o peso necessário na balança/báscula conforme indicado pelo visor a piscar/intermitente.</li> </ul>
	<ul style="list-style-type: none"> <li>• Uma vez estabilizada, pressione  para calibrá-la. (pressione ESC para sair da calibração e voltar ao menu LF1).</li> </ul> <p>A CALIBRAÇÃO SERÁ TERMINADA E A BALANÇA/BÁSCULA VOLTARÁ AUTOMATICAMENTE À MODALIDADE DE PESAGEM.</p>



## CONFIGURAÇÃO LF2

### VISOR

### DESCRIÇÃO E SEQUÊNCIA DE UTILIZAÇÃO

#### PRIMEIRO PASSO

262 144

#### SEGUNDO PASSO

1 0 0 0 0 1

A B C D E F

- VISUALIZAÇÃO DAS CONTAS INTERNAS
- VALORES POSSÍVEIS DOS PARÂMETROS DE CONFIGURAÇÃO

A: Sistema Métrico	0:NO	1: kg	2:T	3:g
B: Sistema Americano	0:NO	1: lb	2:lb oz	
C: outras unidades	0:NO	1: TW kg	2:HK kg	3:VISS
D: PCS	0:OFF	1: ON		
E: intervalo duplo	0:OFF	1: multi intervalo	2: intervalo multi	
F: unidades de calibração		1: utilizar unidades métricas	2: utilizar unidades americanas	

lb oz não podem ser seleccionadas como unidades de calibração.

A balança/báscula não nos permitirá continuar para o próximo passo se houver um erro durante a programação.

#### TERCEIRO PASSO

LF2



262 144



10000 1



000000 kg



d 0.0kg



d.v 0 1



LF2



Depois de introduzir os parâmetros LF2, o visor mostrará a última configuração guardada. Todos os passos devem ser completados, caso contrário o visor continuará com a configuração anterior.

Proceda com a calibração do peso após LF2.

- Pressione a tecla para iniciar e mostrará o VALOR INTERNO. Pressione para sair do menu e a balança/báscula será automaticamente reiniciada.

- Pressione para continuar com a configuração. (pressione para sair da configuração e voltar ao menu LF2).

- Utilize , e , e depois para seleccionar as UNIDADES E MODALIDADE DE PESAGEM de acordo com a tabela acima. (pressione para sair da calibração e voltar ao menu LF2).

- Utilize , e , e depois para seleccionar a CAPACIDADE MÁXIMA, tendo em conta o número de casas decimais que vai seleccionar no passo seguinte. (pressione para sair da calibração e voltar ao menu LF2).

- Utilize , e depois para mover o ponto decimal. (pressione para sair da configuração e voltar ao menu LF2).

- Utilize e depois para alterar o escalão (pressione para sair da configuração e voltar ao menu LF2).

- Utilize , e para continuar com outras configurações ou pressione para sair do menu e a balança/báscula será automaticamente reiniciada).

## VELOCIDADE DO CONVERSOR AD *LF 4*















**SPEED 1** velocidade standard/padrão 15Hz.

**SPEED 2** velocidade alta 30Hz.



**SPEED 3** velocidade baixa 7,5Hz















\*Esta função é bloqueada quando UF-5 está na modalidade HOLD 1.

\*O valor por defeito é 1

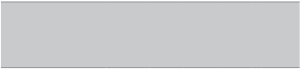
VISOR	DESCRIÇÃO E SEQUÊNCIA DE UTILIZAÇÃO
 	<ul style="list-style-type: none"> <li>• Pressione  para iniciar ou  para sair do menu e a balança/báscula será automaticamente reiniciada.</li> </ul>
 	<ul style="list-style-type: none"> <li>• Utilize  e depois  para seleccionar a velocidade do conversor AD (pressione  para sair da configuração e voltar ao menu LF4)</li> </ul>
 	<ul style="list-style-type: none"> <li>• Utilize ,  e depois  para continuar com outras configurações ou pressione  para sair do menu e a balança/báscula será automaticamente reiniciada.</li> </ul>

## INVISUAL *LF 5*

VISOR	DESCRIÇÃO E SEQUÊNCIA DE UTILIZAÇÃO
 	<p><b>ZP 0</b> OFF</p> <p><b>ZP 1</b> Uma divisão não será mostrada se estiver a zero</p> <p><b>ZP 2</b> Duas divisões não serão mostradas se estiverem a zero</p> <p><b>ZP 3</b> Três divisões não serão mostradas se estiverem a zero</p> <p><b>ZP 4</b> Quatro divisões não serão mostradas se estiverem a zero</p> <p><b>ZP 5</b> Cinco divisões não serão mostradas se estiverem a zero</p> <p>*Esta função é bloqueada quando UF-5 está na modalidade HOLD 1</p> <p>*O valor por defeito é ZP 0</p>

VISOR	DESCRIÇÃO E SEQUÊNCIA DE UTILIZAÇÃO
 	<ul style="list-style-type: none"> <li>• Pressione  para iniciar ou  para sair do menu e a balança/báscula será automaticamente reiniciada.</li> </ul>
 	<ul style="list-style-type: none"> <li>• Utilize  e depois  para seleccionar quantas divisões serão apresentadas a zero. (pressione <b>ESC</b> para sair da configuração e voltar ao menu LF4)</li> </ul>
 	<ul style="list-style-type: none"> <li>• Utilize ,  e depois  para continuar com outras configurações ou pressione  para sair do menu e a balança/báscula será automaticamente reiniciada.</li> </ul>

## CONFORMIDADE DE APROVAÇÃO LF 6

VISOR

DESCRIÇÃO E SEQUÊNCIA DE UTILIZAÇÃO

0M LF 6

nonE Versão não verificada OIML versão verificada

**NÃO ALTERAR ESTE PARÂMETRO EM CIRCUNSTÂNCIA ALGUMA.**

A alteração deste parâmetro implica o bloqueio de certas funcionalidades.



## GRAVIDADE LF 7

\*Introduza a gravidade da sua área antes de efetuar a primeira calibração.

\*Introduza a gravidade alvo depois de efetuar a calibração.

\*O valor da gravidade será negado se for superior a 9,83217 (gravidade do pólo) ou inferior a 9,78031 (gravidade do equador).



Valor padrão de fábrica: 9 801

VISOR

DESCRIÇÃO E SEQUÊNCIA DE UTILIZAÇÃO

LF 7



- Pressione  para continuar ou  para sair do menu e a balança/báscula será automaticamente reiniciada.

--00--

- O ecrã mostrará o número de pré-calibração durante um segundo.

9,8035



- Pressione  para continuar.

9,8035



- Utilize ,  e , **0 ~ 9** e depois  para introduzir o valor da gravidade.. (pressione ESC para sair da configuração e voltar ao menu LF 7).

## ZERO INICIAL LF 8

**SEIZ Y** redefine o ponto zero cada vez que a balança/báscula é reiniciada



**SEIZ n** redefinição do ponto zero OFF

VISOR

DESCRIÇÃO e SEQUÊNCIA DE UTILIZAÇÃO





LF 8



- Pressione  para iniciar ou  para sair do menu e a balança/báscula será automaticamente reiniciada.





Seiz Y



- Utilize ,  e depois  para seleccionar a modalidade de zero inicial. (pressione  para sair da configuração e voltar ao menu LF8)

LF 8



- Utilize ,  e depois  para continuar com outras configurações ou pressione  para sair do menu e a balança/báscula será automaticamente reiniciada.

## 11. MENSAGENS DE ERRO

MENSAGENS	DESCRIÇÃO
	Ponto zero demasiado alto
	Ponto zero demasiado alto
	Ponto zero demasiado alto
	Ponto zero demasiado baixo
	Ponto zero demasiado baixo
	O peso não é estável.
	O código interno não é estável
	Sobrecarga
	Sobrecarga
	Sobrecarga
	Correção da linearidade incorreta ou cancelamento da correção da linearidade
	O peso é demasiado baixo
	O código interno é demasiado baixo
	E2ROM anormal
	O preço total é superior a 999999
	O volume da bateria é demasiado baixo

## **12. GARANTIA**

Este indicador tem garantia contra todos os defeitos de fabrico e materiais durante um período de 1 ano a partir da data de entrega.

Durante este período, a GIROPÈS será responsável pela reparação do indicador.

Esta garantia não inclui danos causados por utilização indevida ou sobrecargas.

A garantia não cobre os custos de envio (portes) necessários para a reparação do indicador.







marca propiedad de | est une marque de | marchio di proprietà di |  
trade mark propriety of | Warenzeichen Proprietät von | marca registada propietade de:

Pol. Empordà Internacional C/ Molló, 3  
17469 VILAMALLA - (Girona) SPAIN  
T. (34) 972 527 212

**GIROPES**)