

## Retail scale



RS232



PRINT INC



BAT INT



AC/DC



VERIF

### FEATURES:

- Weight-price-cost scale.
- CE Approval model with verification of series.
- House in ABS.
- Stainless steel pan.
- Dimensions of the pan: 365x235 mm
- Column with screen at both sides.
- Column in painted aluminum and base in ABS.
- Individual screens for the total weight, unit price, total price and tare.
- Sum up sales up to 3 sellers.
- 56 keys of direct price and 99 additional PLU.
- Internal rechargeable battery of 6V. It lasts to up to 200 hours. (and 12 hours of loading).
- Power supply with adaptor AC/DC 240Vac 50Hz.
- Temperature of use: -10 °C +40 °C.
- Output RS232.
- Configurable independent menu: to rate calculation (able/disabled) and automatic opening of the drawer purse with the transaction (able/disabled).
- Printer included. Paper of 57 mm of width and 51 mm.
- Alphanumerical configurable receipt.
- 2 headers with four lines and a foot line.
- Receipt number identification and series number to comply with the current regulation of simplified invoice.
- Report printing formats:
  - Sales per type: PLU's, pieces, kilograms. With total addition and information of the total VAT price.
  - It shows line per line all the operations done. It includes subtotal and total (there is no VAT breakdown)
  - Printed with VAT breakdown
  - Reports of sales of PLU's:
    - Normal: Transactions done with date and hour
    - Summarized: Transactions done
    - Selectable period of the sales report (whole days) and header.
- Printing languages: Spanish, French, English, Portuguese and Italian.



### FUNCTIONS:

- Accumulation
- Sum ups sales to up to 3 sellers

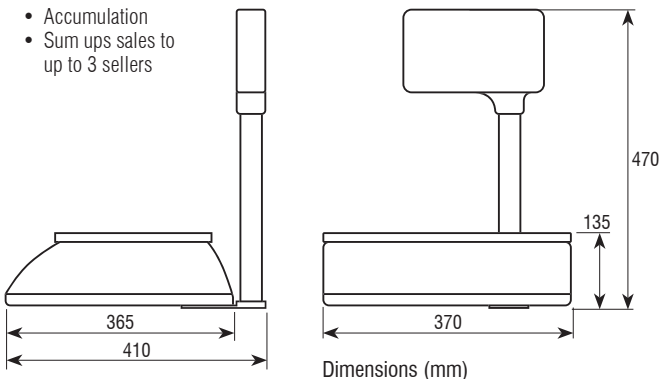

Sample tiquet



Printer included

Code #	Capacity (kg)	Readout (g)	Pan dimensions (mm)	Packing dimensions (mm)	Packing weight (kg)
260474	6/15	2/5	365x235	255x525x465	9
260473	15/30	5/10	365x235	255x525x465	9

### Accessories

Code #	Accessories description
270417	Pan to weight fruit
910020	Plastic cash drawer 330A
910094	Metal cash drawer 410